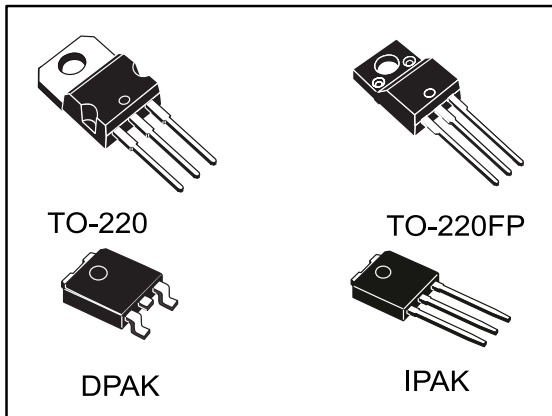

---

**Precision 500 mA regulators**

---

Datasheet - production data

**Description**

The L78M series of three-terminal positive regulators is available in TO-220, TO-220FP, DPAK and IPAK packages and with several fixed output voltages, making it useful in a wide range of applications. These regulators can provide local on-card regulation, eliminating the distribution problems associated with single point regulation. Each type employs internal current limiting, thermal shutdown and safe area protection, resulting it essentially indestructible. If adequate heat sinking is provided, they can deliver over 0.5 A output current. Although designed primarily as fixed voltage regulators, these devices can be used with external components to obtain adjustable voltage and currents.

**Features**

- Output current to 0.5 A
- Output voltages of 5; 6; 8; 9; 10; 12; 15; 24 V
- Thermal overload protection
- Short circuit protection
- Output transition SOA protection
- Output voltage tolerance: 2 % (AB and AC versions) or 4 % (C version)
- Guaranteed in extended temperature range

---

**Contents**

<b>1</b>	<b>Diagram</b> .....	<b>3</b>
<b>2</b>	<b>Pin configuration</b> .....	<b>4</b>
<b>3</b>	<b>Maximum ratings</b> .....	<b>5</b>
<b>4</b>	<b>Test circuits</b> .....	<b>6</b>
<b>5</b>	<b>Electrical characteristics</b> .....	<b>7</b>
<b>6</b>	<b>Typical performance</b> .....	<b>22</b>
<b>7</b>	<b>Applications information</b> .....	<b>24</b>
	7.1 Design considerations.....	24
<b>8</b>	<b>Package information</b> .....	<b>28</b>
	8.1 TO-220 (single gauge) package information .....	29
	8.2 TO-220 (dual gauge) package information.....	31
	8.3 TO-220FP package information .....	33
	8.4 DPAK (TO-252) type A package information.....	35
	8.5 DPAK (TO-252) type I package information .....	38
	8.6 DPAK packing information .....	41
	8.7 IPAK package information.....	43
<b>9</b>	<b>Ordering information</b> .....	<b>45</b>
<b>10</b>	<b>Revision history</b> .....	<b>46</b>

# 1 Diagram

Figure 1: Block diagram

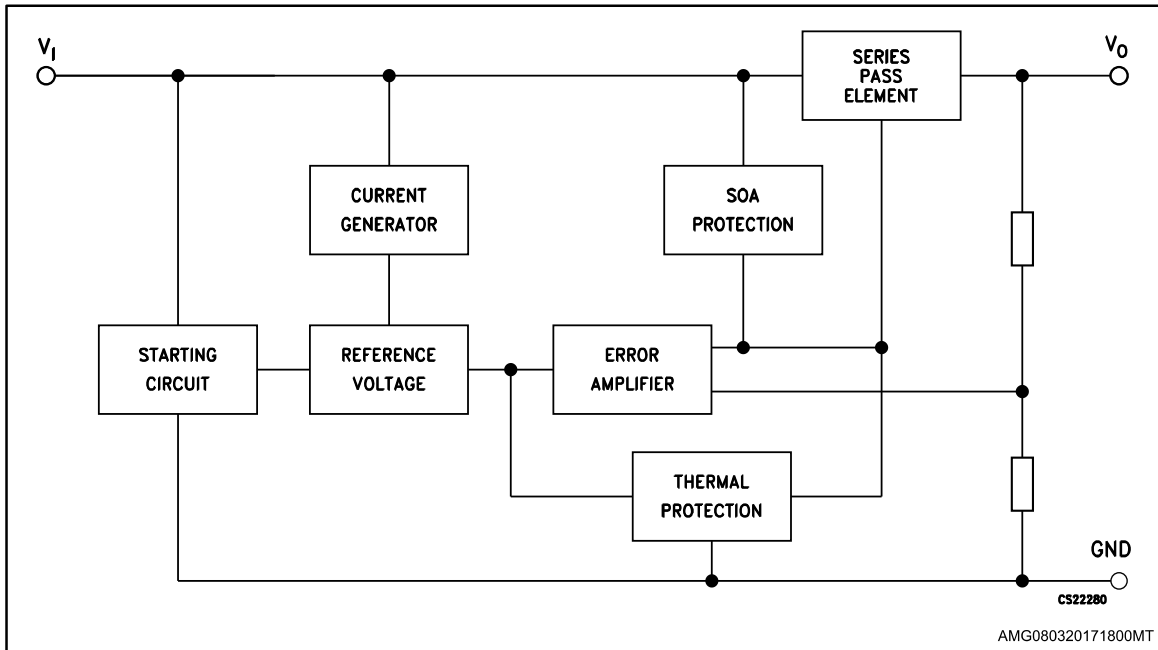

## 2 Pin configuration

Figure 2: Pin connections (top view)

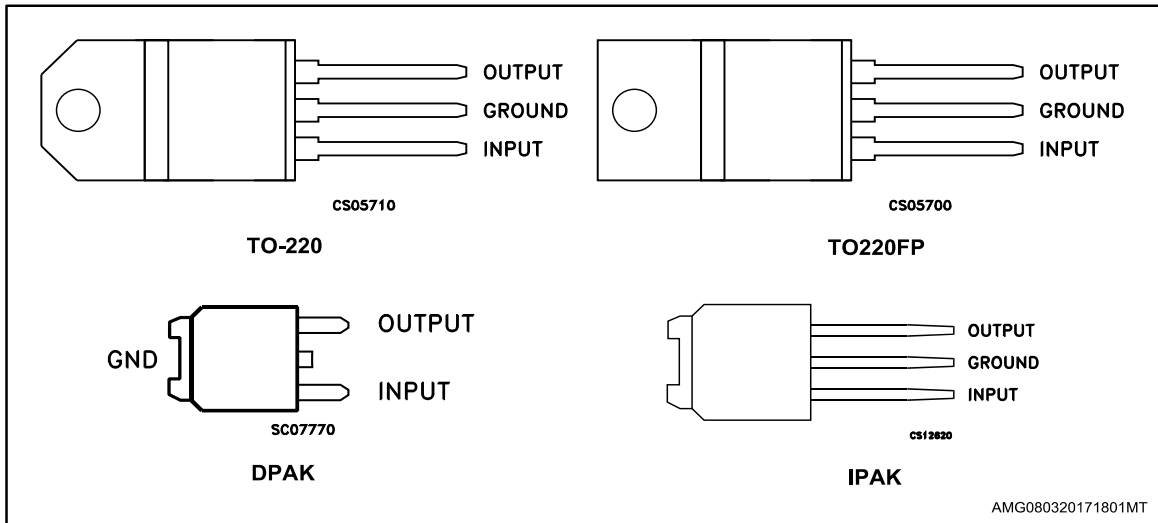
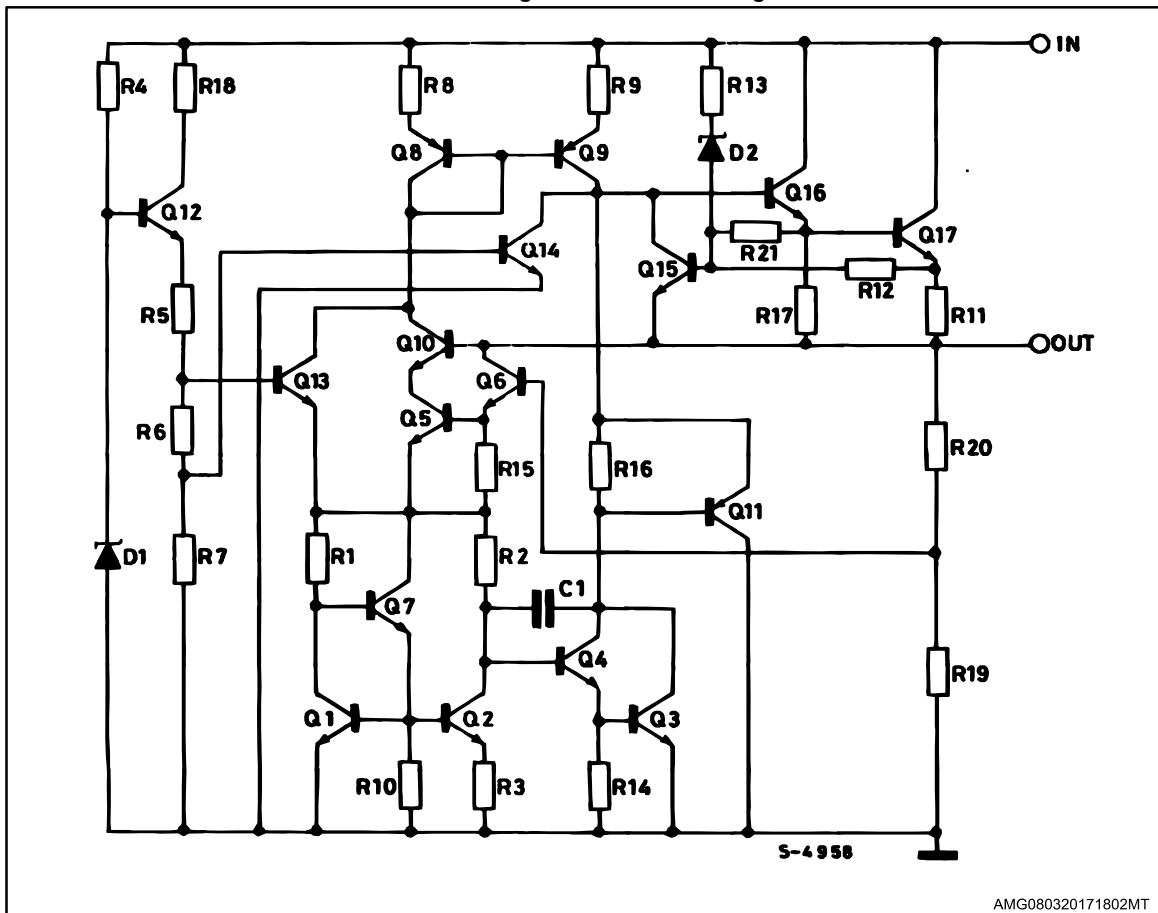

Figure 3: Schematic diagram



### 3 Maximum ratings

Table 1: Absolute maximum ratings

Symbol	Parameter	Value	Unit
$V_i$	DC input voltage	for $V_o = 5$ to $18$ V	35
		for $V_o = 20, 24$ V	40
$I_o$	Output current	Internally limited	mA
$P_D$	Power dissipation	Internally limited	mW
$T_{STG}$	Storage temperature range	- 65 to 150	°C
$T_{OP}$	Operating junction temperature range	for L78MxxAC	0 to 125
		for L78MxxAB	-40 to 125
		for L78MxxC	0 to 150



Absolute maximum ratings are those values beyond which damage to the device may occur. Functional operation under these condition is not implied.

Table 2: Thermal data

Symbol	Parameter	TO-220	TO-220FP	DPAK	IPAK	Unit
$R_{thJC}$	Thermal resistance junction-case	5	5	8	8	°C/W
$R_{thJA}$	Thermal resistance junction-ambient	50	60	100	100	°C/W

Figure 4: Application circuit

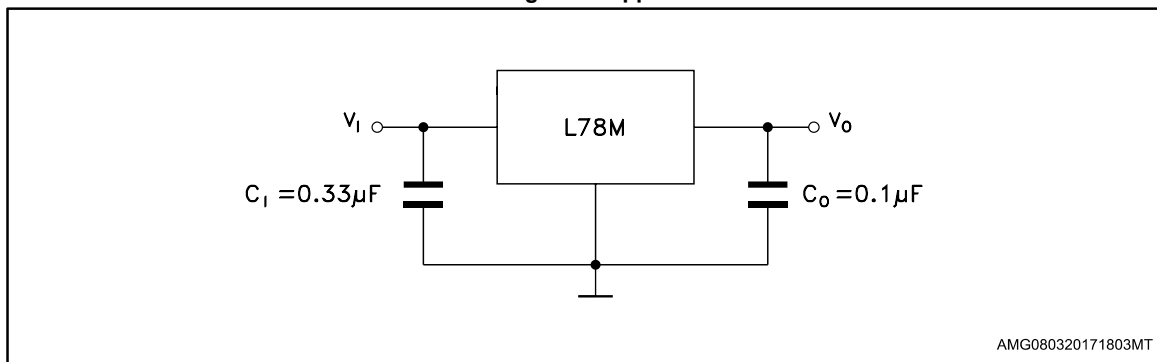

## 4 Test circuits

Figure 5: DC parameter

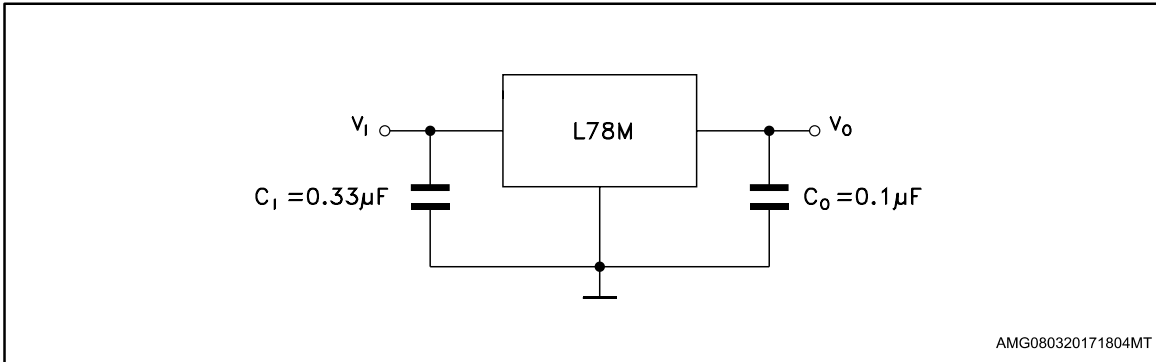

Figure 6: Load regulation

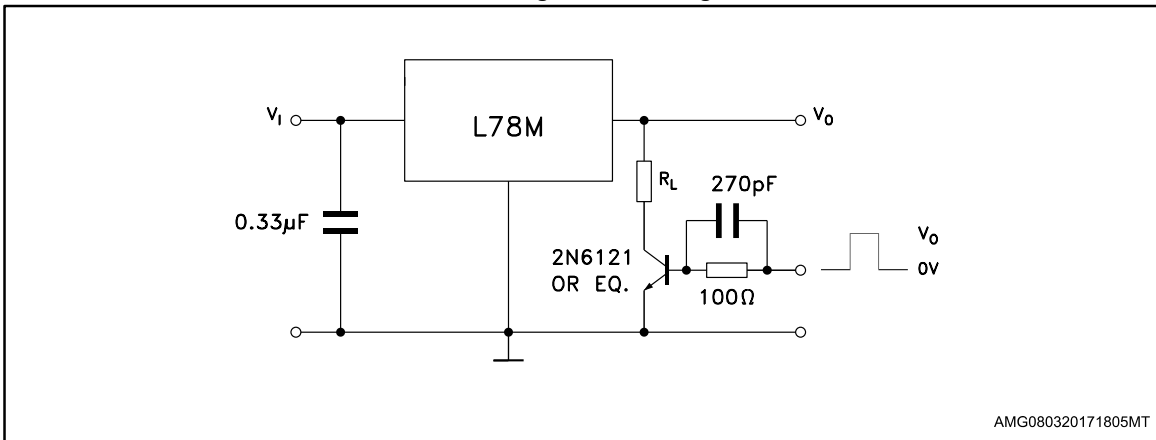
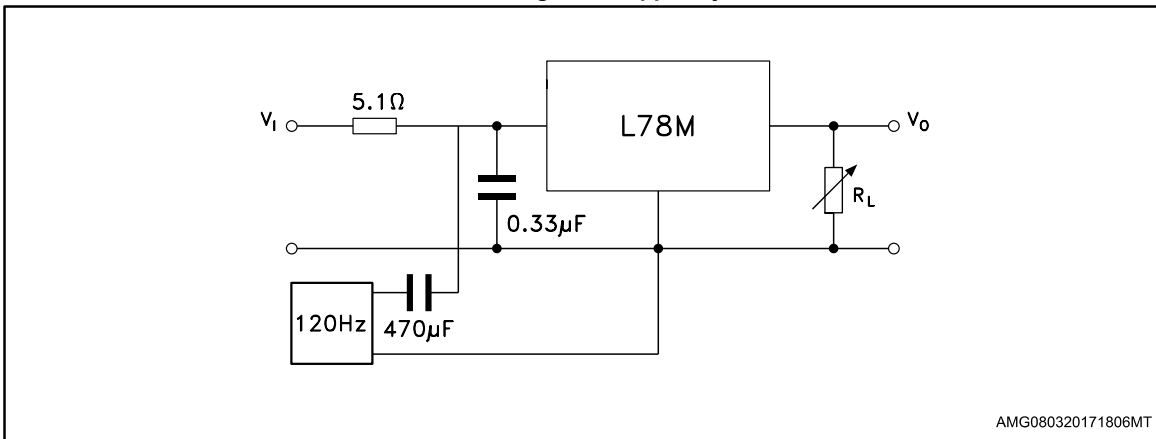

Figure 7: Ripple rejection



## 5 Electrical characteristics

Refer to the test circuits,  $T_J = 25\text{ °C}$ ,  $V_I = 10\text{ V}$ ,  $I_O = 350\text{ mA}$ ,  $C_I = 0.33\text{ }\mu\text{F}$ ,  $C_O = 0.1\text{ }\mu\text{F}$  unless otherwise specified.

Table 3: Electrical characteristics of L78M05C

Symbol	Parameter	Test conditions	Min.	Typ.	Max.	Unit
$V_O$	Output voltage		4.8	5	5.2	V
$V_O$	Output voltage	$I_O = 5\text{ to }350\text{ mA}$ , $V_I = 7\text{ to }20\text{ V}$	4.75	5	5.25	V
$\Delta V_O$	Line regulation	$V_I = 7\text{ to }25\text{ V}$ , $I_O = 200\text{ mA}$			100	mV
		$V_I = 8\text{ to }25\text{ V}$ , $I_O = 200\text{ mA}$			50	
$\Delta V_O$	Load regulation	$I_O = 5\text{ to }500\text{ mA}$ , $T_J = 25\text{ °C}$			100	mV
		$I_O = 5\text{ to }200\text{ mA}$ , $T_J = 25\text{ °C}$			50	
$I_d$	Quiescent current				6	mA
$\Delta I_d$	Quiescent current change	$I_O = 5\text{ to }350\text{ mA}$			0.5	mA
		$I_O = 200\text{ mA}$ , $V_I = 8\text{ to }25\text{ V}$			0.8	
$\Delta V_O/\Delta T$	Output voltage drift	$I_O = 5\text{ mA}$ , $T_J = 0\text{ to }125\text{ °C}$		-0.5		mV/°C
SVR	Supply voltage rejection	$V_I = 8\text{ to }18\text{ V}$ , $f = 120\text{ Hz}$ , $I_O = 300\text{ mA}$	62			dB
eN	Output noise voltage	$B = 10\text{ Hz to }100\text{ kHz}$		40		$\mu\text{V}$
$V_d$	Dropout voltage			2		V
$I_{sc}$	Short circuit current	$V_I = 35\text{ V}$		300		mA

Refer to the test circuits,  $V_I = 10\text{ V}$ ,  $I_O = 350\text{ mA}$ ,  $C_I = 0.33\text{ }\mu\text{F}$ ,  $C_O = 0.1\text{ }\mu\text{F}$ ,  $T_J = -40$  to  $125\text{ }^\circ\text{C}$  (AB),  $T_J = 0$  to  $125\text{ }^\circ\text{C}$  (AC) unless otherwise specified.

Table 4: Electrical characteristics of L78M05A

Symbol	Parameter	Test conditions	Min.	Typ.	Max.	Unit
$V_O$	Output voltage	$T_J = 25\text{ }^\circ\text{C}$	4.9	5	5.1	V
$V_O$	Output voltage	$I_O = 5$ to $350\text{ mA}$ , $V_I = 7$ to $20\text{ V}$	4.8	5	5.2	V
$\Delta V_O$	Line regulation	$V_I = 7$ to $25\text{ V}$ , $I_O = 200\text{ mA}$ , $T_J = 25\text{ }^\circ\text{C}$			100	mV
		$V_I = 8$ to $25\text{ V}$ , $I_O = 200\text{ mA}$ , $T_J = 25\text{ }^\circ\text{C}$			50	
$\Delta V_O$	Load regulation	$I_O = 5$ to $500\text{ mA}$ , $T_J = 25\text{ }^\circ\text{C}$			100	mV
		$I_O = 5$ to $200\text{ mA}$ , $T_J = 25\text{ }^\circ\text{C}$			50	
$I_d$	Quiescent current	$T_J = 25\text{ }^\circ\text{C}$			6	mA
$\Delta I_d$	Quiescent current change	$I_O = 5$ to $350\text{ mA}$			0.5	mA
		$I_O = 200\text{ mA}$ , $V_I = 8$ to $25\text{ V}$			0.8	
$\Delta V_O/\Delta T$	Output voltage drift	$I_O = 5\text{ mA}$		-0.5		mV/ $^\circ\text{C}$
SVR	Supply voltage rejection	$V_I = 8$ to $18\text{ V}$ , $f = 120\text{ Hz}$ , $I_O = 300\text{ mA}$ , $T_J = 25\text{ }^\circ\text{C}$	62			dB
eN	Output noise voltage	$B = 10\text{ Hz}$ to $100\text{ kHz}$ , $T_J = 25\text{ }^\circ\text{C}$		40		$\mu\text{V}$
$V_d$	Dropout voltage	$T_J = 25\text{ }^\circ\text{C}$		2		V
$I_{sc}$	Short circuit current	$T_J = 25\text{ }^\circ\text{C}$ , $V_I = 35\text{ V}$		300		mA
$I_{scp}$	Short circuit peak current	$T_J = 25\text{ }^\circ\text{C}$		700		mA



Refer to the test circuits,  $T_J = 25\text{ °C}$ ,  $V_I = 11\text{ V}$ ,  $I_O = 350\text{ mA}$ ,  $C_I = 0.33\text{ }\mu\text{F}$ ,  $C_O = 0.1\text{ }\mu\text{F}$  unless otherwise specified.

Table 5: Electrical characteristics of L78M06C

Symbol	Parameter	Test conditions	Min.	Typ.	Max.	Unit
$V_O$	Output voltage		5.75	6	6.25	V
$V_O$	Output voltage	$I_O = 5\text{ to }350\text{ mA}$ , $V_I = 8\text{ to }21\text{ V}$	5.7	6	6.3	V
$\Delta V_O$	Line regulation	$V_I = 8\text{ to }25\text{ V}$ , $I_O = 200\text{ mA}$			100	mV
		$V_I = 9\text{ to }25\text{ V}$ , $I_O = 200\text{ mA}$			50	
$\Delta V_O$	Load regulation	$I_O = 5\text{ to }500\text{ mA}$ , $T_J = 25\text{ °C}$			120	mV
		$I_O = 5\text{ to }200\text{ mA}$ , $T_J = 25\text{ °C}$			60	
$I_d$	Quiescent current				6	mA
$\Delta I_d$	Quiescent current change	$I_O = 5\text{ to }350\text{ mA}$			0.5	mA
		$I_O = 200\text{ mA}$ , $V_I = 9\text{ to }25\text{ V}$			0.8	
$\Delta V_O/\Delta T$	Output voltage drift	$I_O = 5\text{ mA}$ , $T_J = 0\text{ to }125\text{ °C}$		-0.5		mV/°C
SVR	Supply voltage rejection	$V_I = 9\text{ to }19\text{ V}$ , $f = 120\text{ Hz}$ , $I_O = 300\text{ mA}$	59			dB
eN	Output noise voltage	$B = 10\text{ Hz to }100\text{ kHz}$		45		$\mu\text{V}$
$V_d$	Dropout voltage			2		V
$I_{sc}$	Short circuit current	$V_I = 35\text{ V}$		270		mA

Refer to the test circuits,  $V_I = 11\text{ V}$ ,  $I_O = 350\text{ mA}$ ,  $C_I = 0.33\text{ }\mu\text{F}$ ,  $C_O = 0.1\text{ }\mu\text{F}$ ,  $T_J = -40$  to  $125\text{ }^\circ\text{C}$  (AB),  $T_J = 0$  to  $125\text{ }^\circ\text{C}$  (AC) unless otherwise specified.

Table 6: Electrical characteristics of L78M06A

Symbol	Parameter	Test conditions	Min.	Typ.	Max.	Unit
$V_O$	Output voltage	$T_J = 25\text{ }^\circ\text{C}$	5.88	6	6.12	V
$V_O$	Output voltage	$I_O = 5$ to $350\text{ mA}$ , $V_I = 8$ to $21\text{ V}$	5.75	6	6.3	V
$DV_O$	Line regulation	$V_I = 8$ to $25\text{ V}$ , $I_O = 200\text{ mA}$ , $T_J = 25\text{ }^\circ\text{C}$			100	mV
		$V_I = 9$ to $25\text{ V}$ , $I_O = 200\text{ mA}$ , $T_J = 25\text{ }^\circ\text{C}$			30	
$\Delta V_O$	Load regulation	$I_O = 5$ to $500\text{ mA}$ , $T_J = 25\text{ }^\circ\text{C}$			120	mV
		$I_O = 5$ to $200\text{ mA}$ , $T_J = 25\text{ }^\circ\text{C}$			60	
$I_d$	Quiescent current	$T_J = 25\text{ }^\circ\text{C}$			6	mA
$\Delta I_d$	Quiescent current change	$I_O = 5$ to $350\text{ mA}$			0.5	mA
		$I_O = 200\text{ mA}$ , $V_I = 9$ to $25\text{ V}$			0.8	
$\Delta V_O/\Delta T$	Output voltage drift	$I_O = 5\text{ mA}$		-0.5		mV/ $^\circ\text{C}$
SVR	Supply voltage rejection	$V_I = 9$ to $19\text{ V}$ , $f = 120\text{ Hz}$ , $I_O = 300\text{ mA}$ , $T_J = 25\text{ }^\circ\text{C}$	59			dB
eN	Output noise voltage	$B = 10\text{ Hz}$ to $100\text{ kHz}$		45		$\mu\text{V}$
$V_d$	Dropout voltage	$T_J = 25\text{ }^\circ\text{C}$		2		V
$I_{sc}$	Short circuit current	$T_J = 25\text{ }^\circ\text{C}$ , $V_I = 35\text{ V}$		270		mA
$I_{scp}$	Short circuit peak current	$T_J = 25\text{ }^\circ\text{C}$		700		mA

Refer to the test circuits,  $T_J = 25\text{ }^\circ\text{C}$ ,  $V_I = 14\text{ V}$ ,  $I_O = 350\text{ mA}$ ,  $C_I = 0.33\text{ }\mu\text{F}$ ,  $C_O = 0.1\text{ }\mu\text{F}$  unless otherwise specified.

Table 7: Electrical characteristics of L78M08C

Symbol	Parameter	Test conditions	Min.	Typ.	Max.	Unit
$V_O$	Output voltage		7.7	8	8.3	V
$V_O$	Output voltage	$I_O = 5\text{ to }350\text{ mA}$ , $V_I = 10.5\text{ to }23\text{ V}$	7.6	8	8.4	V
$\Delta V_O$	Line regulation	$V_I = 10.5\text{ to }25\text{ V}$ , $I_O = 200\text{ mA}$			100	mV
		$V_I = 11\text{ to }25\text{ V}$ , $I_O = 200\text{ mA}$			50	
$\Delta V_O$	Load regulation	$I_O = 5\text{ to }500\text{ mA}$ , $T_J = 25\text{ }^\circ\text{C}$			160	mV
		$I_O = 5\text{ to }200\text{ mA}$ , $T_J = 25\text{ }^\circ\text{C}$			80	
$I_d$	Quiescent current				6	mA
$\Delta I_d$	Quiescent current change	$I_O = 5\text{ to }350\text{ mA}$			0.5	mA
		$I_O = 200\text{ mA}$ , $V_I = 10.5\text{ to }25\text{ V}$			0.8	
$\Delta V_O/\Delta T$	Output voltage drift	$I_O = 5\text{ mA}$ , $T_J = 0\text{ to }125\text{ }^\circ\text{C}$		-0.5		mV/°C
SVR	Supply voltage rejection	$V_I = 11.5\text{ to }21.5\text{ V}$ , $f = 120\text{ Hz}$ , $I_O = 300\text{ mA}$	56			dB
eN	Output noise voltage	$B = 10\text{ Hz to }100\text{ kHz}$		52		$\mu\text{V}$
$V_d$	Dropout voltage			2		V
$I_{sc}$	Short circuit current	$V_I = 35\text{ V}$		250		mA

Refer to the test circuits,  $V_I = 14\text{ V}$ ,  $I_O = 350\text{ mA}$ ,  $C_I = 0.33\text{ }\mu\text{F}$ ,  $C_O = 0.1\text{ }\mu\text{F}$ ,  $T_J = -40$  to  $125\text{ }^\circ\text{C}$  (AB),  $T_J = 0$  to  $125\text{ }^\circ\text{C}$  (AC) unless otherwise specified.

Table 8: Electrical characteristics of L78M08A

Symbol	Parameter	Test conditions	Min.	Typ.	Max.	Unit
$V_O$	Output voltage	$T_J = 25\text{ }^\circ\text{C}$	7.84	8	8.16	V
$V_O$	Output voltage	$I_O = 5$ to $350\text{ mA}$ , $V_I = 10.5$ to $23\text{ V}$	7.7	8	8.3	V
$\Delta V_O$	Line regulation	$V_I = 10.5$ to $25\text{ V}$ , $I_O = 200\text{ mA}$ , $T_J = 25\text{ }^\circ\text{C}$			100	mV
		$V_I = 11$ to $25\text{ V}$ , $I_O = 200\text{ mA}$ , $T_J = 25\text{ }^\circ\text{C}$			30	
$\Delta V_O$	Load regulation	$I_O = 5$ to $500\text{ mA}$ , $T_J = 25\text{ }^\circ\text{C}$			160	mV
		$I_O = 5$ to $200\text{ mA}$ , $T_J = 25\text{ }^\circ\text{C}$			80	
$I_d$	Quiescent current	$T_J = 25\text{ }^\circ\text{C}$			6	mA
$\Delta I_d$	Quiescent current change	$I_O = 5$ to $350\text{ mA}$			0.5	mA
		$I_O = 200\text{ mA}$ , $V_I = 10.5$ to $25\text{ V}$			0.8	
$\Delta V_O/\Delta T$	Output voltage drift	$I_O = 5\text{ mA}$		-0.5		mV/ $^\circ\text{C}$
SVR	Supply voltage rejection	$V_I = 11.5$ to $21.5\text{ V}$ , $f = 120\text{ Hz}$ , $I_O = 300\text{ mA}$ , $T_J = 25\text{ }^\circ\text{C}$	56			dB
eN	Output noise voltage	$B = 10\text{ Hz}$ to $100\text{ kHz}$ , $T_J = 25\text{ }^\circ\text{C}$		52		$\mu\text{V}$
$V_d$	Dropout voltage	$T_J = 25\text{ }^\circ\text{C}$		2		V
$I_{sc}$	Short circuit current	$T_J = 25\text{ }^\circ\text{C}$ , $V_I = 35\text{ V}$		250		mA
$I_{scp}$	Short circuit peak current	$T_J = 25\text{ }^\circ\text{C}$		700		mA

Refer to the test circuits,  $T_J = 25\text{ °C}$ ,  $V_I = 15\text{ V}$ ,  $I_O = 350\text{ mA}$ ,  $C_I = 0.33\text{ }\mu\text{F}$ ,  $C_O = 0.1\text{ }\mu\text{F}$  unless otherwise specified.

Table 9: Electrical characteristics of L78M09C

Symbol	Parameter	Test conditions	Min.	Typ.	Max.	Unit
$V_O$	Output voltage		8.65	9	9.35	V
$V_O$	Output voltage	$I_O = 5\text{ to }350\text{ mA}$ , $V_I = 11.5\text{ to }24\text{ V}$	8.55	9	9.45	V
$\Delta V_O$	Line regulation	$V_I = 11.5\text{ to }25\text{ V}$ , $I_O = 200\text{ mA}$			100	mV
		$V_I = 12\text{ to }25\text{ V}$ , $I_O = 200\text{ mA}$			50	
$\Delta V_O$	Load regulation	$I_O = 5\text{ to }500\text{ mA}$ , $T_J = 25\text{ °C}$			180	mV
		$I_O = 5\text{ to }200\text{ mA}$ , $T_J = 25\text{ °C}$			90	
$I_d$	Quiescent current				6	mA
$\Delta I_d$	Quiescent current change	$I_O = 5\text{ to }350\text{ mA}$			0.5	mA
		$I_O = 200\text{ mA}$ , $V_I = 11.5\text{ to }25\text{ V}$			0.8	
$\Delta V_O/\Delta T$	Output voltage drift	$I_O = 5\text{ mA}$ , $T_J = 0\text{ to }125\text{ °C}$		-0.5		mV/°C
SVR	Supply voltage rejection	$V_I = 12.5\text{ to }23\text{ V}$ , $f = 120\text{ Hz}$ , $I_O = 300\text{ mA}$	56			dB
eN	Output noise voltage	$B = 10\text{ Hz to }100\text{ kHz}$		58		$\mu\text{V}$
$V_d$	Dropout voltage			2		V
$I_{sc}$	Short circuit current	$V_I = 35\text{ V}$		250		mA

Refer to the test circuits,  $V_I = 15\text{ V}$ ,  $I_O = 350\text{ mA}$ ,  $C_I = 0.33\text{ }\mu\text{F}$ ,  $C_O = 0.1\text{ }\mu\text{F}$ ,  $T_J = -40$  to  $125\text{ }^\circ\text{C}$  (AB),  $T_J = 0$  to  $125\text{ }^\circ\text{C}$  (AC) unless otherwise specified.

Table 10: Electrical characteristics of L78M09A

Symbol	Parameter	Test conditions	Min.	Typ.	Max.	Unit
$V_O$	Output voltage	$T_J = 25\text{ }^\circ\text{C}$	8.82	9	9.18	V
$V_O$	Output voltage	$I_O = 5$ to $350\text{ mA}$ , $V_I = 11.5$ to $24\text{ V}$	8.64	9	9.36	V
$\Delta V_O$	Line regulation	$V_I = 11.5$ to $25\text{ V}$ , $I_O = 200\text{ mA}$ , $T_J = 25\text{ }^\circ\text{C}$			100	mV
		$V_I = 12$ to $25\text{ V}$ , $I_O = 200\text{ mA}$ , $T_J = 25\text{ }^\circ\text{C}$			30	
$\Delta V_O$	Load regulation	$I_O = 5$ to $500\text{ mA}$ , $T_J = 25\text{ }^\circ\text{C}$			180	mV
		$I_O = 5$ to $200\text{ mA}$ , $T_J = 25\text{ }^\circ\text{C}$			90	
$I_d$	Quiescent current	$T_J = 25\text{ }^\circ\text{C}$			6	mA
$\Delta I_d$	Quiescent current change	$I_O = 5$ to $350\text{ mA}$			0.5	mA
		$I_O = 200\text{ mA}$ , $V_I = 11.5$ to $25\text{ V}$			0.8	
$\Delta V_O/\Delta T$	Output voltage drift	$I_O = 5\text{ mA}$		-0.5		mV/ $^\circ\text{C}$
SVR	Supply voltage rejection	$V_I = 12.5$ to $23\text{ V}$ , $f = 120\text{ Hz}$ , $I_O = 300\text{ mA}$ , $T_J = 25\text{ }^\circ\text{C}$	56			dB
eN	Output noise voltage	$B = 10\text{ Hz}$ to $100\text{ kHz}$ , $T_J = 25\text{ }^\circ\text{C}$		52		$\mu\text{V}$
$V_d$	Dropout voltage	$T_J = 25\text{ }^\circ\text{C}$		2		V
$I_{sc}$	Short circuit current	$V_I = 35\text{ V}$ , $T_J = 25\text{ }^\circ\text{C}$		250		mA
$I_{scp}$	Short circuit peak current	$T_J = 25\text{ }^\circ\text{C}$		700		mA

Refer to the test circuits,  $V_I = 16\text{ V}$ ,  $I_O = 350\text{ mA}$ ,  $C_I = 0.33\text{ }\mu\text{F}$ ,  $C_O = 0.1\text{ }\mu\text{F}$ ,  $T_J = -40$  to  $125\text{ }^\circ\text{C}$  (AB),  $T_J = 0$  to  $125\text{ }^\circ\text{C}$  (AC) unless otherwise specified.

Table 11: Electrical characteristics of L78M10A

Symbol	Parameter	Test conditions	Min.	Typ.	Max.	Unit
$V_O$	Output voltage	$T_J = 25\text{ }^\circ\text{C}$	9.8	10	10.2	V
$V_O$	Output voltage	$I_O = 5$ to $350\text{ mA}$ , $V_I = 12.5$ to $25\text{ V}$	9.6	10	10.4	V
$\Delta V_O$	Line regulation	$V_I = 12.5$ to $30\text{ V}$ , $I_O = 200\text{ mA}$ , $T_J = 25\text{ }^\circ\text{C}$			100	mV
		$V_I = 13$ to $30\text{ V}$ , $I_O = 200\text{ mA}$ , $T_J = 25\text{ }^\circ\text{C}$			30	
$\Delta V_O$	Load regulation	$I_O = 5$ to $500\text{ mA}$ , $T_J = 25\text{ }^\circ\text{C}$			200	mV
		$I_O = 5$ to $200\text{ mA}$ , $T_J = 25\text{ }^\circ\text{C}$			100	
$I_d$	Quiescent current	$T_J = 25\text{ }^\circ\text{C}$			6	mA
$\Delta I_d$	Quiescent current change	$I_O = 5$ to $350\text{ mA}$			0.5	mA
		$I_O = 200\text{ mA}$ , $V_I = 12.5$ to $30\text{ V}$			0.8	
$\Delta V_O/\Delta T$	Output voltage drift	$I_O = 5\text{ mA}$		-0.5		mV/ $^\circ\text{C}$
SVR	Supply voltage rejection	$V_I = 13.5$ to $24\text{ V}$ , $f = 120\text{ Hz}$ , $I_O = 300\text{ mA}$ , $T_J = 25\text{ }^\circ\text{C}$	56			dB
eN	Output noise voltage	$B = 10\text{ Hz}$ to $100\text{ kHz}$ , $T_J = 25\text{ }^\circ\text{C}$		64		$\mu\text{V}$
$V_d$	Dropout voltage	$T_J = 25\text{ }^\circ\text{C}$		2		V
$I_{sc}$	Short circuit current	$V_I = 35\text{ V}$ , $T_J = 25\text{ }^\circ\text{C}$		245		mA
$I_{scp}$	Short circuit peak current	$T_J = 25\text{ }^\circ\text{C}$		700		mA

Refer to the test circuits,  $T_J = 25\text{ °C}$ ,  $V_I = 19\text{ V}$ ,  $I_O = 350\text{ mA}$ ,  $C_I = 0.33\text{ }\mu\text{F}$ ,  $C_O = 0.1\text{ }\mu\text{F}$  unless otherwise specified.

Table 12: Electrical characteristics of L78M12C

Symbol	Parameter	Test conditions	Min.	Typ.	Max.	Unit
$V_O$	Output voltage		11.5	12	12.5	V
$V_O$	Output voltage	$I_O = 5\text{ to }350\text{ mA}$ , $V_I = 14.5\text{ to }27\text{ V}$	11.4	12	12.6	V
$\Delta V_O$	Line regulation	$V_I = 14.5\text{ to }30\text{ V}$ , $I_O = 200\text{ mA}$			100	mV
		$V_I = 16\text{ to }30\text{ V}$ , $I_O = 200\text{ mA}$			50	
$\Delta V_O$	Load regulation	$I_O = 5\text{ to }500\text{ mA}$ , $T_J = 25\text{ °C}$			240	mV
		$I_O = 5\text{ to }200\text{ mA}$ , $T_J = 25\text{ °C}$			120	
$I_d$	Quiescent current				6	mA
$\Delta I_d$	Quiescent current change	$I_O = 5\text{ to }350\text{ mA}$			0.5	mA
		$I_O = 200\text{ mA}$ , $V_I = 14.5\text{ to }30\text{ V}$			0.8	
$\Delta V_O/\Delta T$	Output voltage drift	$I_O = 5\text{ mA}$ , $T_J = 0\text{ to }125\text{ °C}$		-1		mV/°C
SVR	Supply voltage rejection	$V_I = 15\text{ to }25\text{ V}$ , $f = 120\text{ Hz}$ , $I_O = 300\text{ mA}$	55			dB
eN	Output noise voltage	$B = 10\text{ Hz to }100\text{ kHz}$		75		$\mu\text{V}$
$V_d$	Dropout voltage			2		V
$I_{sc}$	Short circuit current	$V_I = 35\text{ V}$		240		mA



Refer to the test circuits,  $V_I = 19\text{ V}$ ,  $I_O = 350\text{ mA}$ ,  $C_I = 0.33\text{ }\mu\text{F}$ ,  $C_O = 0.1\text{ }\mu\text{F}$ ,  $T_J = -40$  to  $125\text{ }^\circ\text{C}$  (AB),  $T_J = 0$  to  $125\text{ }^\circ\text{C}$  (AC) unless otherwise specified.

Table 13: Electrical characteristics of L78M12A

Symbol	Parameter	Test conditions	Min.	Typ.	Max.	Unit
$V_O$	Output voltage	$T_J = 25\text{ }^\circ\text{C}$	11.75	12	12.25	V
$V_O$	Output voltage	$I_O = 5$ to $350\text{ mA}$ , $V_I = 14.5$ to $27\text{ V}$	11.5	12	12.5	V
$\Delta V_O$	Line regulation	$V_I = 14.5$ to $30\text{ V}$ , $I_O = 200\text{ mA}$ , $T_J = 25\text{ }^\circ\text{C}$			100	mV
		$V_I = 16$ to $30\text{ V}$ , $I_O = 200\text{ mA}$ , $T_J = 25\text{ }^\circ\text{C}$			30	
$\Delta V_O$	Load regulation	$I_O = 5$ to $500\text{ mA}$ , $T_J = 25\text{ }^\circ\text{C}$			240	mV
		$I_O = 5$ to $200\text{ mA}$ , $T_J = 25\text{ }^\circ\text{C}$			120	
$I_d$	Quiescent current	$T_J = 25\text{ }^\circ\text{C}$			6	mA
$\Delta I_d$	Quiescent current change	$I_O = 5$ to $350\text{ mA}$			0.5	mA
		$I_O = 200\text{ mA}$ , $V_I = 14.5$ to $30\text{ V}$			0.8	
$\Delta V_O/\Delta T$	Output voltage drift	$I_O = 5\text{ mA}$		-1		mV/ $^\circ\text{C}$
SVR	Supply voltage rejection	$V_I = 15$ to $25\text{ V}$ , $f = 120\text{ Hz}$ , $I_O = 300\text{ mA}$ , $T_J = 25\text{ }^\circ\text{C}$	55			dB
eN	Output noise voltage	$B = 10\text{ Hz}$ to $100\text{ kHz}$ , $T_J = 25\text{ }^\circ\text{C}$		75		$\mu\text{V}$
$V_d$	Dropout voltage	$T_J = 25\text{ }^\circ\text{C}$		2		V
$I_{sc}$	Short circuit current	$V_I = 35\text{ V}$ , $T_J = 25\text{ }^\circ\text{C}$		240		mA
$I_{scp}$	Short circuit peak current	$T_J = 25\text{ }^\circ\text{C}$		700		mA

Refer to the test circuits,  $T_J = 25\text{ °C}$ ,  $V_I = 23\text{ V}$ ,  $I_O = 350\text{ mA}$ ,  $C_I = 0.33\text{ }\mu\text{F}$ ,  $C_O = 0.1\text{ }\mu\text{F}$  unless otherwise specified.

Table 14: Electrical characteristics of L78M15C

Symbol	Parameter	Test conditions	Min.	Typ.	Max.	Unit
$V_O$	Output voltage		14.4	15	15.6	V
$V_O$	Output voltage	$I_O = 5\text{ to }350\text{ mA}$ , $V_I = 17.5\text{ to }30\text{ V}$	14.25	15	15.75	V
$\Delta V_O$	Line regulation	$V_I = 17.5\text{ to }30\text{ V}$ , $I_O = 200\text{ mA}$			100	mV
		$V_I = 20\text{ to }30\text{ V}$ , $I_O = 200\text{ mA}$			50	
$\Delta V_O$	Load regulation	$I_O = 5\text{ to }500\text{ mA}$ , $T_J = 25\text{ °C}$			300	mV
		$I_O = 5\text{ to }200\text{ mA}$ , $T_J = 25\text{ °C}$			150	
$I_d$	Quiescent current				6	mA
$\Delta I_d$	Quiescent current change	$I_O = 5\text{ to }350\text{ mA}$			0.5	mA
		$I_O = 200\text{ mA}$ , $V_I = 17.5\text{ to }30\text{ V}$			0.8	
$\Delta V_O/\Delta T$	Output voltage drift	$I_O = 5\text{ mA}$ , $T_J = 0\text{ to }125\text{ °C}$		-1		mV/°C
SVR	Supply voltage rejection	$V_I = 18.5\text{ to }28.5\text{ V}$ , $f = 120\text{ Hz}$ , $I_O = 300\text{ mA}$	54			dB
eN	Output noise voltage	$B = 10\text{ Hz to }100\text{ kHz}$		90		$\mu\text{V}$
$V_d$	Dropout voltage			2		V
$I_{sc}$	Short circuit current	$V_I = 35\text{ V}$		240		mA

Refer to the test circuits,  $V_I = 23\text{ V}$ ,  $I_O = 350\text{ mA}$ ,  $C_I = 0.33\text{ }\mu\text{F}$ ,  $C_O = 0.1\text{ }\mu\text{F}$ ,  $T_J = -40$  to  $125\text{ }^\circ\text{C}$  (AB),  $T_J = 0$  to  $125\text{ }^\circ\text{C}$  (AC) unless otherwise specified.

Table 15: Electrical characteristics of L78M15A

Symbol	Parameter	Test conditions	Min.	Typ.	Max.	Unit
$V_O$	Output voltage	$T_J = 25\text{ }^\circ\text{C}$	14.7	15	15.3	V
$V_O$	Output voltage	$I_O = 5$ to $350\text{ mA}$ , $V_I = 17.5$ to $30\text{ V}$	14.4	15	15.6	V
$\Delta V_O$	Line regulation	$V_I = 17.5$ to $30\text{ V}$ , $I_O = 200\text{ mA}$ , $T_J = 25\text{ }^\circ\text{C}$			100	mV
		$V_I = 20$ to $30\text{ V}$ , $I_O = 200\text{ mA}$ , $T_J = 25\text{ }^\circ\text{C}$			30	
$\Delta V_O$	Load regulation	$I_O = 5$ to $500\text{ mA}$ , $T_J = 25\text{ }^\circ\text{C}$			300	mV
		$I_O = 5$ to $200\text{ mA}$ , $T_J = 25\text{ }^\circ\text{C}$			150	
$I_d$	Quiescent current	$T_J = 25\text{ }^\circ\text{C}$			6	mA
$\Delta I_d$	Quiescent current change	$I_O = 5$ to $350\text{ mA}$			0.5	mA
		$I_O = 200\text{ mA}$ , $V_I = 17.5$ to $30\text{ V}$			0.8	
$\Delta V_O/\Delta T$	Output voltage drift	$I_O = 5\text{ mA}$		-1		mV/ $^\circ\text{C}$
SVR	Supply voltage rejection	$V_I = 18.5$ to $28.5\text{ V}$ , $f = 120\text{ Hz}$ , $I_O = 300\text{ mA}$ , $T_J = 25\text{ }^\circ\text{C}$	54			dB
eN	Output noise voltage	$B = 10\text{ Hz}$ to $100\text{ kHz}$ , $T_J = 25\text{ }^\circ\text{C}$		90		$\mu\text{V}$
$V_d$	Dropout voltage	$T_J = 25\text{ }^\circ\text{C}$		2		V
$I_{sc}$	Short circuit current	$V_I = 35\text{ V}$ , $T_J = 25\text{ }^\circ\text{C}$		240		mA
$I_{scp}$	Short circuit peak current	$T_J = 25\text{ }^\circ\text{C}$		700		mA

Refer to the test circuits,  $T_J = 25\text{ °C}$ ,  $V_I = 33\text{ V}$ ,  $I_O = 350\text{ mA}$ ,  $C_I = 0.33\text{ }\mu\text{F}$ ,  $C_O = 0.1\text{ }\mu\text{F}$  unless otherwise specified.

Table 16: Electrical characteristics of L78M24C

Symbol	Parameter	Test conditions	Min.	Typ.	Max.	Unit
$V_O$	Output voltage		23	24	25	V
$V_O$	Output voltage	$I_O = 5\text{ to }350\text{ mA}$ , $V_I = 27\text{ to }38\text{ V}$	22.8	24	25.2	V
$\Delta V_O$	Line regulation	$V_I = 27\text{ to }38\text{ V}$ , $I_O = 200\text{ mA}$			100	mV
		$V_I = 28\text{ to }38\text{ V}$ , $I_O = 200\text{ mA}$			50	
$\Delta V_O$	Load regulation	$I_O = 5\text{ to }500\text{ mA}$ , $T_J = 25\text{ °C}$			480	mV
		$I_O = 5\text{ to }200\text{ mA}$ , $T_J = 25\text{ °C}$			240	
$I_d$	Quiescent current				6	mA
$\Delta I_d$	Quiescent current change	$I_O = 5\text{ to }350\text{ mA}$			0.5	mA
		$I_O = 200\text{ mA}$ , $V_I = 27\text{ to }38\text{ V}$			0.8	
$\Delta V_O/\Delta T$	Output voltage drift	$I_O = 5\text{ mA}$ , $T_J = 0\text{ to }125\text{ °C}$		-1.2		mV/°C
SVR	Supply voltage rejection	$V_I = 28\text{ to }38\text{ V}$ , $f = 120\text{ Hz}$ , $I_O = 300\text{ mA}$	50			dB
eN	Output noise voltage	$B = 10\text{ Hz to }100\text{ kHz}$		170		$\mu\text{V}$
$V_d$	Dropout voltage			2		V
$I_{sc}$	Short circuit current	$V_I = 35\text{ V}$		240		mA

Refer to the test circuits,  $V_I = 33\text{ V}$ ,  $I_O = 350\text{ mA}$ ,  $C_I = 0.33\text{ }\mu\text{F}$ ,  $C_O = 0.1\text{ }\mu\text{F}$ ,  $T_J = -40$  to  $125\text{ }^\circ\text{C}$  (AB),  $T_J = 0$  to  $125\text{ }^\circ\text{C}$  (AC) unless otherwise specified.

Table 17: Electrical characteristics of L78M24A

Symbol	Parameter	Test conditions	Min.	Typ.	Max.	Unit
$V_O$	Output voltage	$T_J = 25\text{ }^\circ\text{C}$	23.5	24	24.5	V
$V_O$	Output voltage	$I_O = 5$ to $350\text{ mA}$ , $V_I = 27$ to $38\text{ V}$	23	24	25	V
$\Delta V_O$	Line regulation	$V_I = 27$ to $38\text{ V}$ , $I_O = 200\text{ mA}$ , $T_J = 25\text{ }^\circ\text{C}$			100	mV
		$V_I = 28$ to $38\text{ V}$ , $I_O = 200\text{ mA}$ , $T_J = 25\text{ }^\circ\text{C}$			30	
$\Delta V_O$	Load regulation	$I_O = 5$ to $500\text{ mA}$ , $T_J = 25\text{ }^\circ\text{C}$			480	mV
		$I_O = 5$ to $200\text{ mA}$ , $T_J = 25\text{ }^\circ\text{C}$			240	
$I_d$	Quiescent current	$T_J = 25\text{ }^\circ\text{C}$			6	mA
$\Delta I_d$	Quiescent current change	$I_O = 5$ to $350\text{ mA}$			0.5	mA
		$I_O = 200\text{ mA}$ , $V_I = 27$ to $38\text{ V}$			0.8	
$\Delta V_O/\Delta T$	Output voltage drift	$I_O = 5\text{ mA}$		-1.2		mV/ $^\circ\text{C}$
SVR	Supply voltage rejection	$V_I = 28$ to $38\text{ V}$ , $f = 120\text{ Hz}$ , $I_O = 300\text{ mA}$ , $T_J = 25\text{ }^\circ\text{C}$	50			dB
eN	Output noise voltage	$B = 10\text{ Hz}$ to $100\text{ kHz}$ , $T_J = 25\text{ }^\circ\text{C}$		170		$\mu\text{V}$
$V_d$	Dropout voltage	$T_J = 25\text{ }^\circ\text{C}$		2		V
$I_{sc}$	Short circuit current	$V_I = 35\text{ V}$ , $T_J = 25\text{ }^\circ\text{C}$		240		mA
$I_{scp}$	Short circuit peak current	$T_J = 25\text{ }^\circ\text{C}$		700		mA

## 6 Typical performance

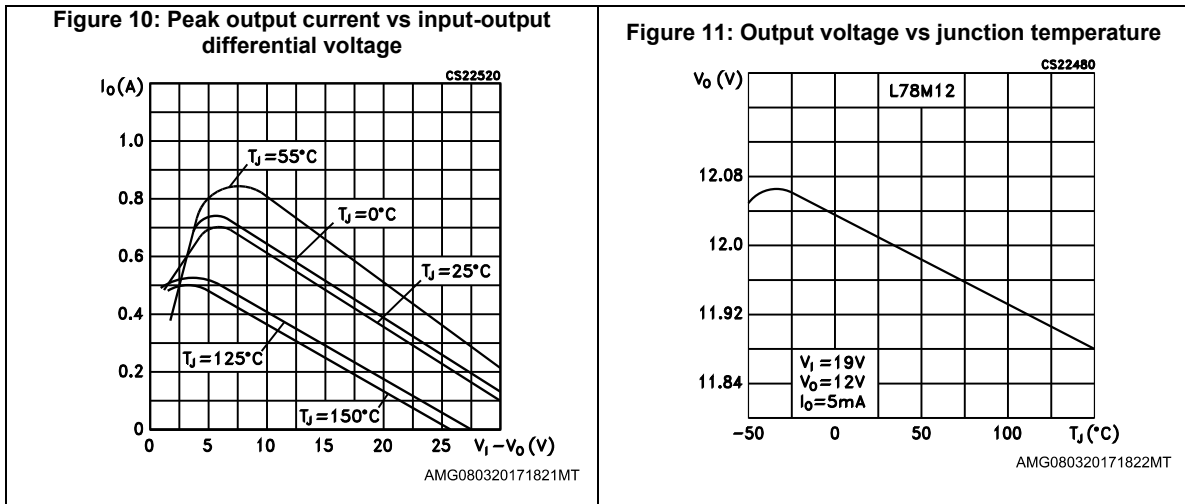
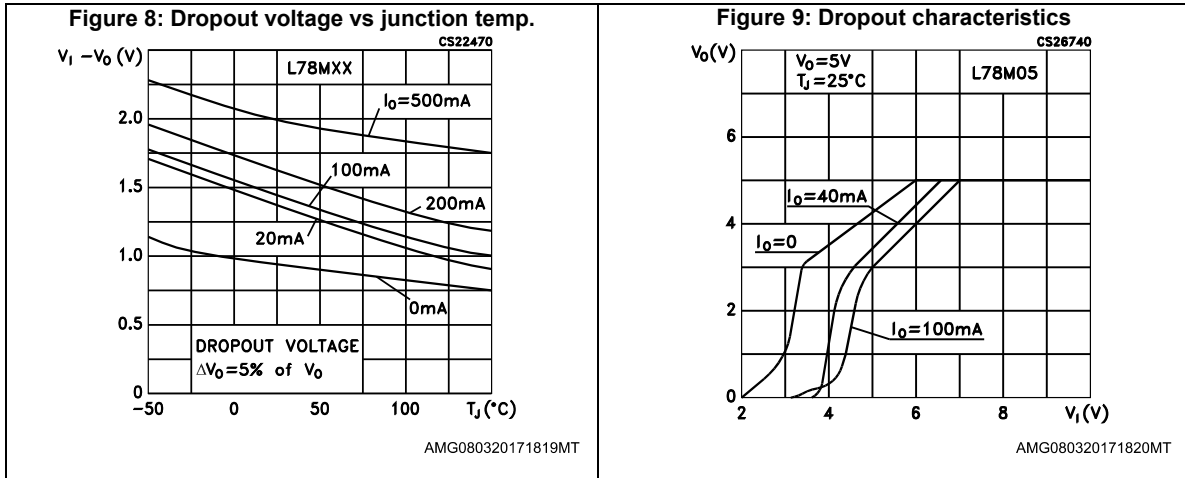

Figure 12: Supply voltage rejection vs frequency

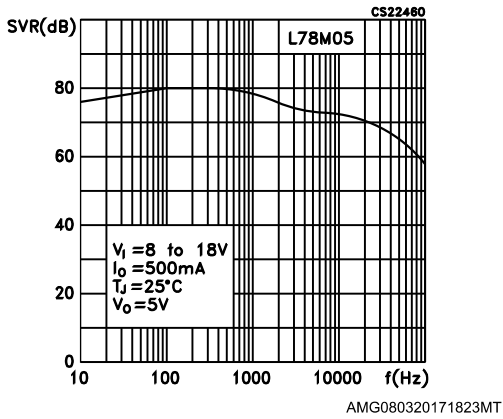

Figure 13: Quiescent current vs junction temperature

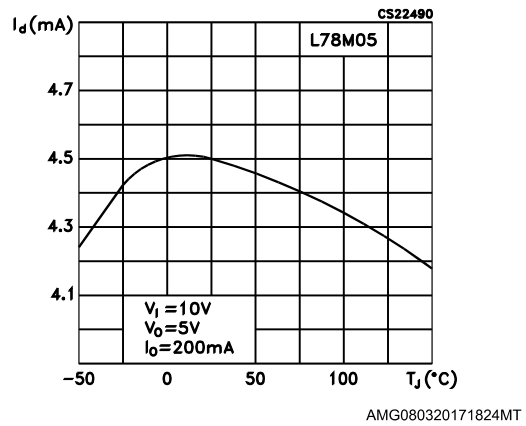

Figure 14: Load transient response

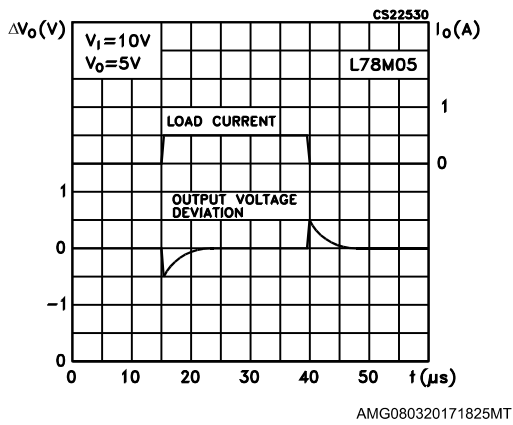

Figure 15: Line transient response

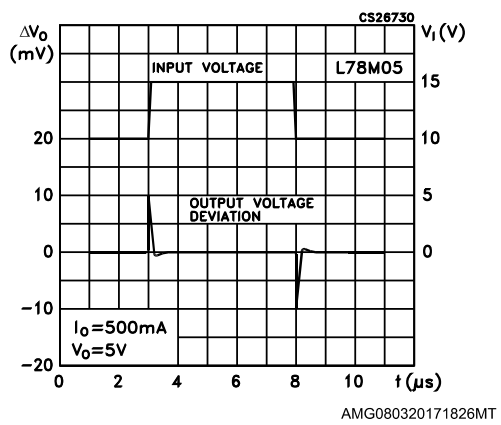
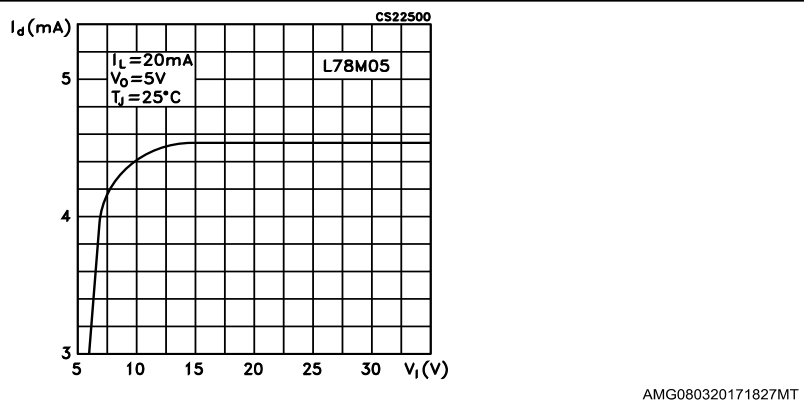

Figure 16: Quiescent current vs input voltage



## 7 Applications information

### 7.1 Design considerations

The L78M series of fixed voltage regulators are designed with thermal overload protection that shuts down the circuit when subjected to an excessive power overload condition, internal short-circuit protection that limits the maximum current the circuit will pass, and output transistor safe-area compensation that reduces the output short-circuit as the voltage across the pass transistor is increased. In many low current applications, compensation capacitors are not required. However, it is recommended that the regulator input be bypassed with a capacitor if the regulator is connected to the power supply filter with long wire lengths, or if the output load capacitance is large. An input bypass capacitor should be selected to provide good high-frequency characteristics to insure stable operation under all load conditions. A  $0.33\ \mu\text{F}$  or larger tantalum, mylar, or other capacitor having low internal impedance at high frequencies should be chosen. The bypass capacitor should be mounted with the shortest possible leads directly across the regulators input terminals. Normally good construction techniques should be used to minimize ground loops and lead resistance drops since the regulator has no external sense lead.

Figure 17: Fixed output regulator

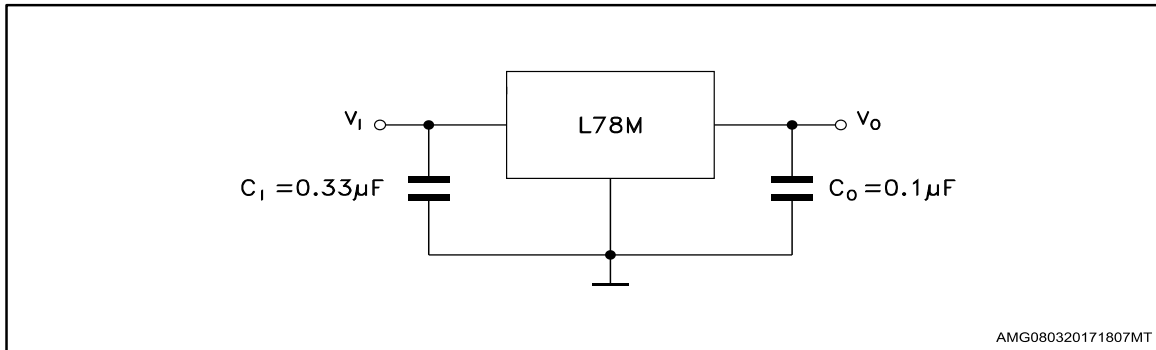

Although no output capacitor is needed for stability,  $C_o$  improves transient response if present.  $C_i$  is required if the regulator is located an appreciable distance from the power supply filter.

Figure 18: Constant current regulator

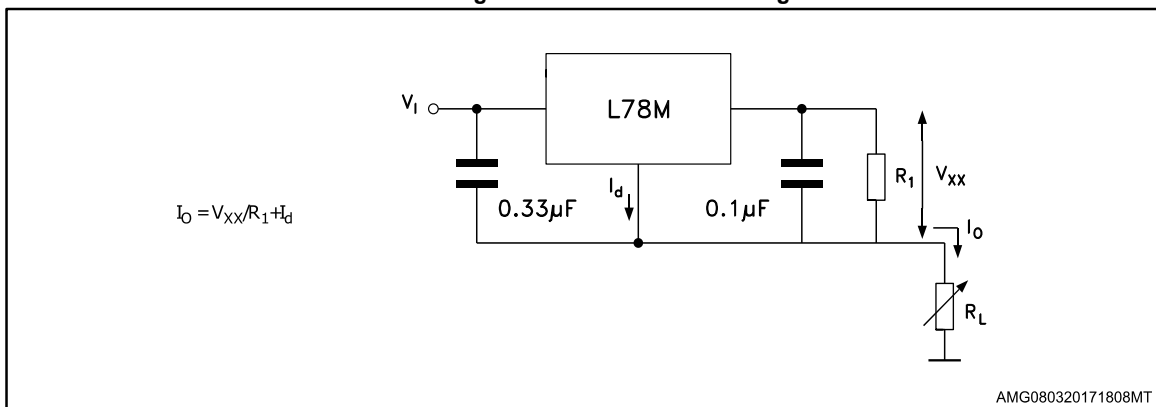



Figure 19: Circuit for increasing output voltage

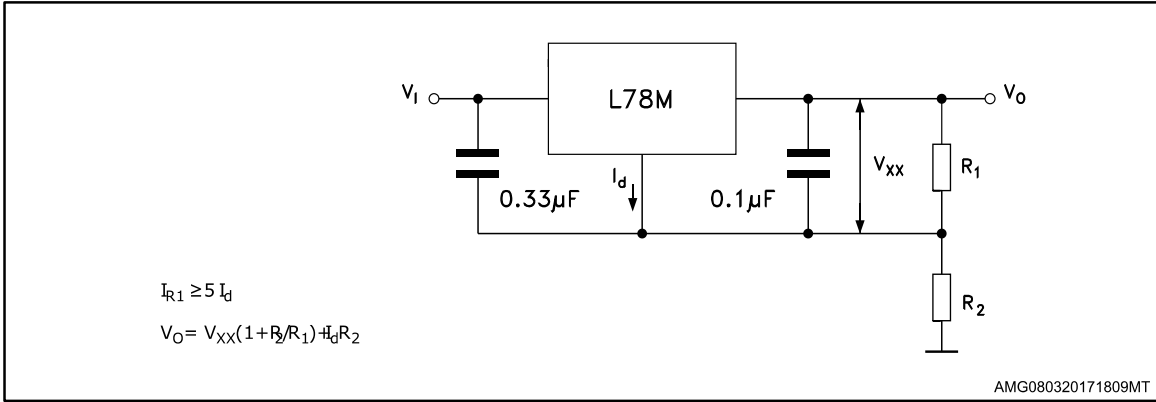

Figure 20: Adjustable output regulator (7 to 30 V)

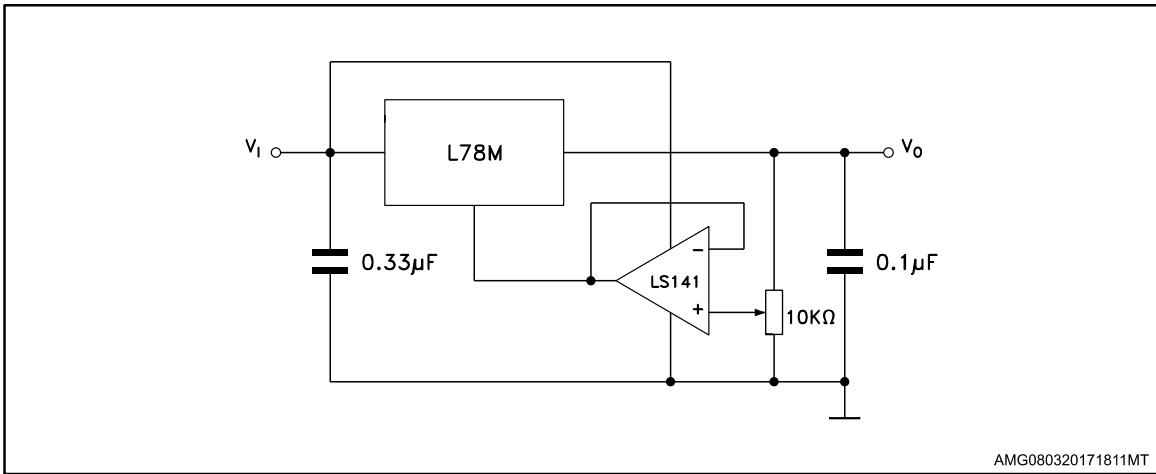

Figure 21: 0.5 to 10 V regulator

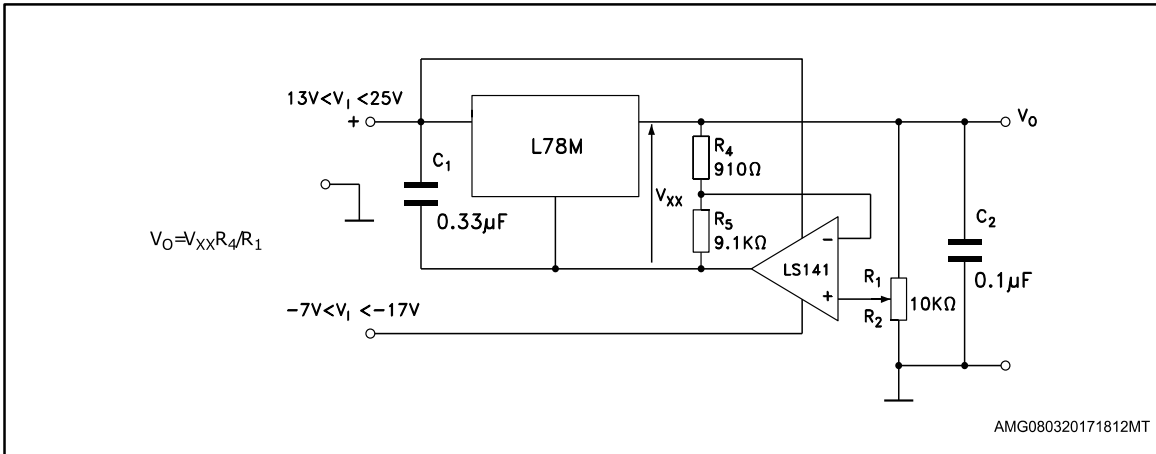

Figure 22: High current voltage regulator

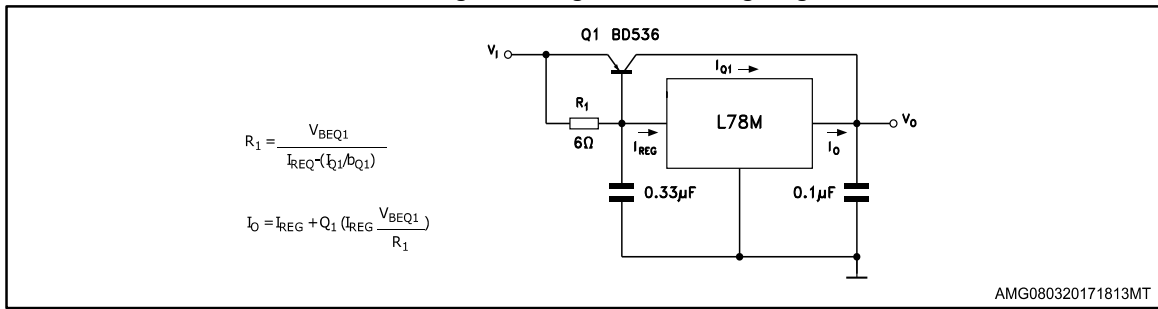

Figure 23: High output current with short circuit protection

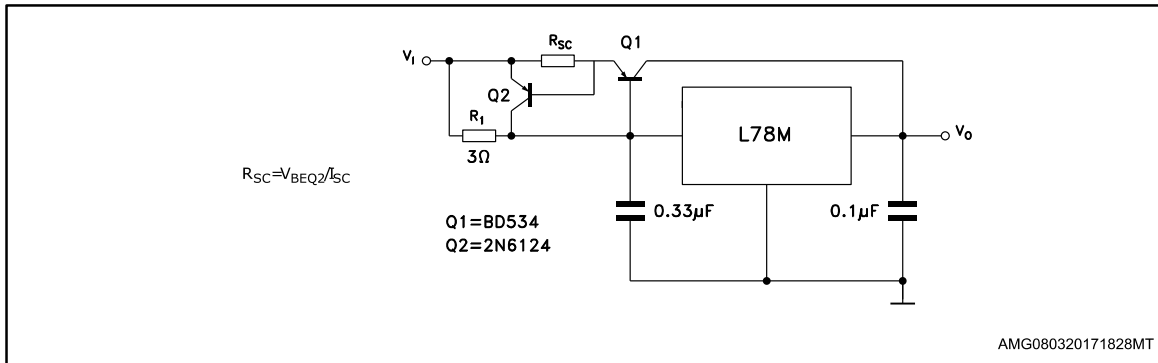

Figure 24: Tracking voltage regulator

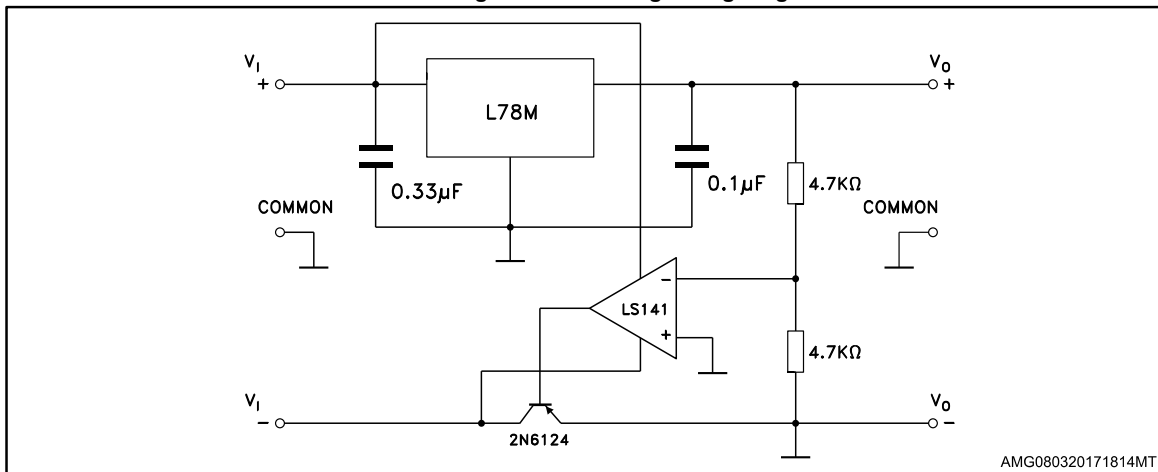

Figure 25: High input voltage circuit

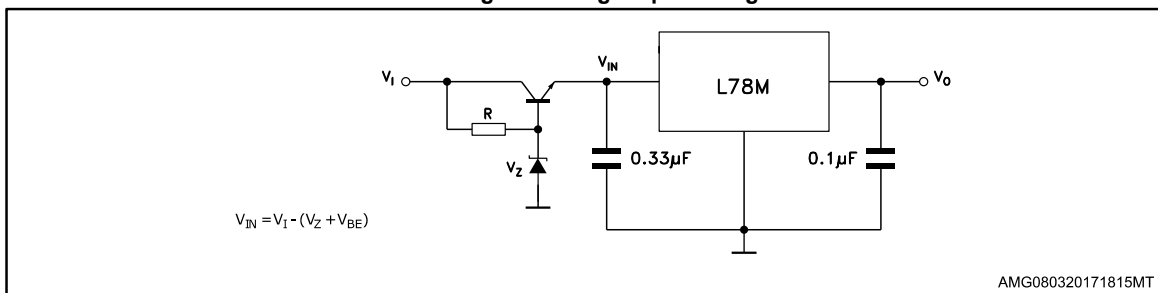

Figure 26: Reducing power dissipation with dropping resistor

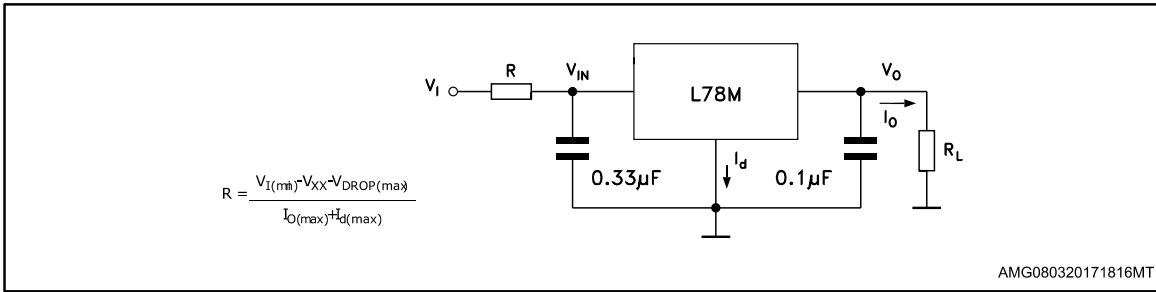
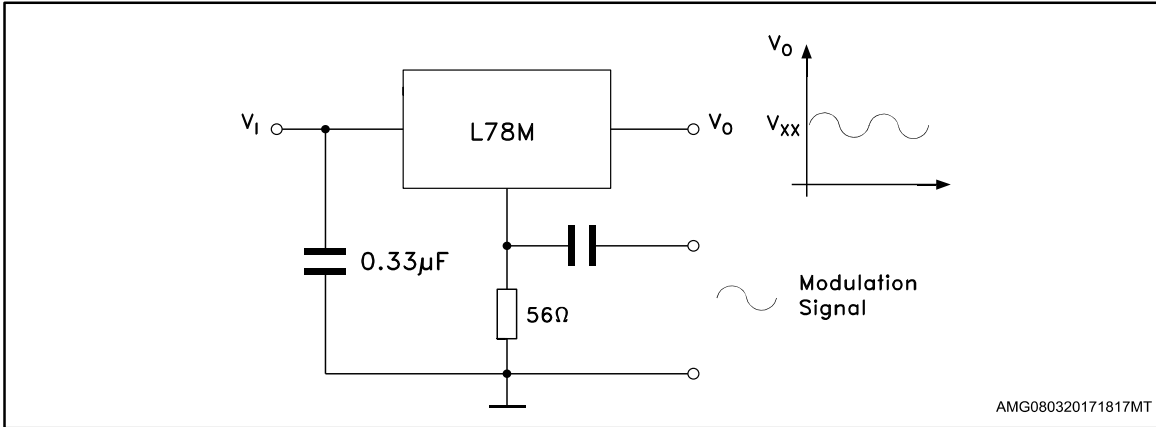
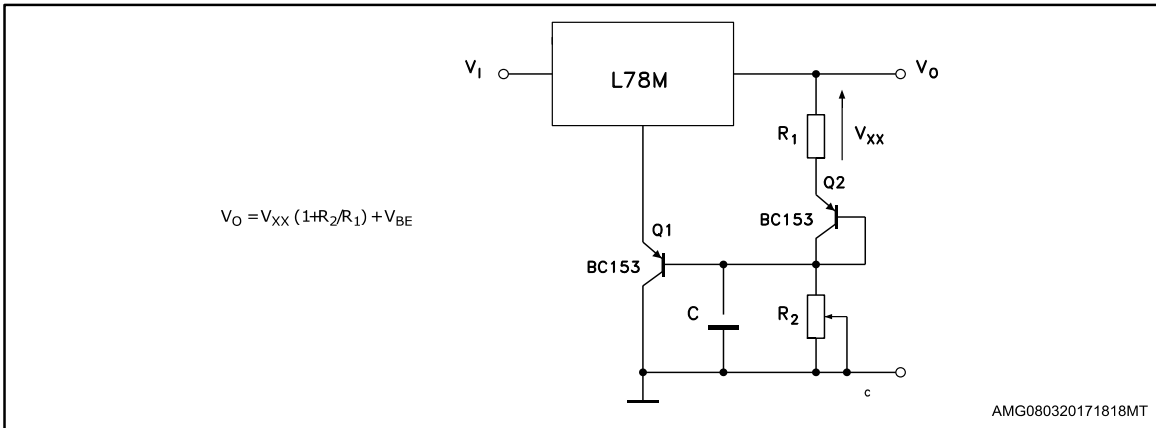

Figure 27: Power AM modulator (unity voltage gain, IO ≤ 0.5)



The circuit performs well up to 100 kHz.

Figure 28: Adjustable output voltage with temperature compensation



Q2 is connected as a diode in order to compensate the variation of the Q1 V<sub>BE</sub> with the temperature. C allows a slow rise time of the V<sub>O</sub>.

## 8 Package information

In order to meet environmental requirements, ST offers these devices in different grades of ECOPACK® packages, depending on their level of environmental compliance. ECOPACK® specifications, grade definitions and product status are available at: [www.st.com](http://www.st.com). ECOPACK® is an ST trademark.

### 8.1 TO-220 (single gauge) package information

Figure 29: TO-220 (single gauge) package outline

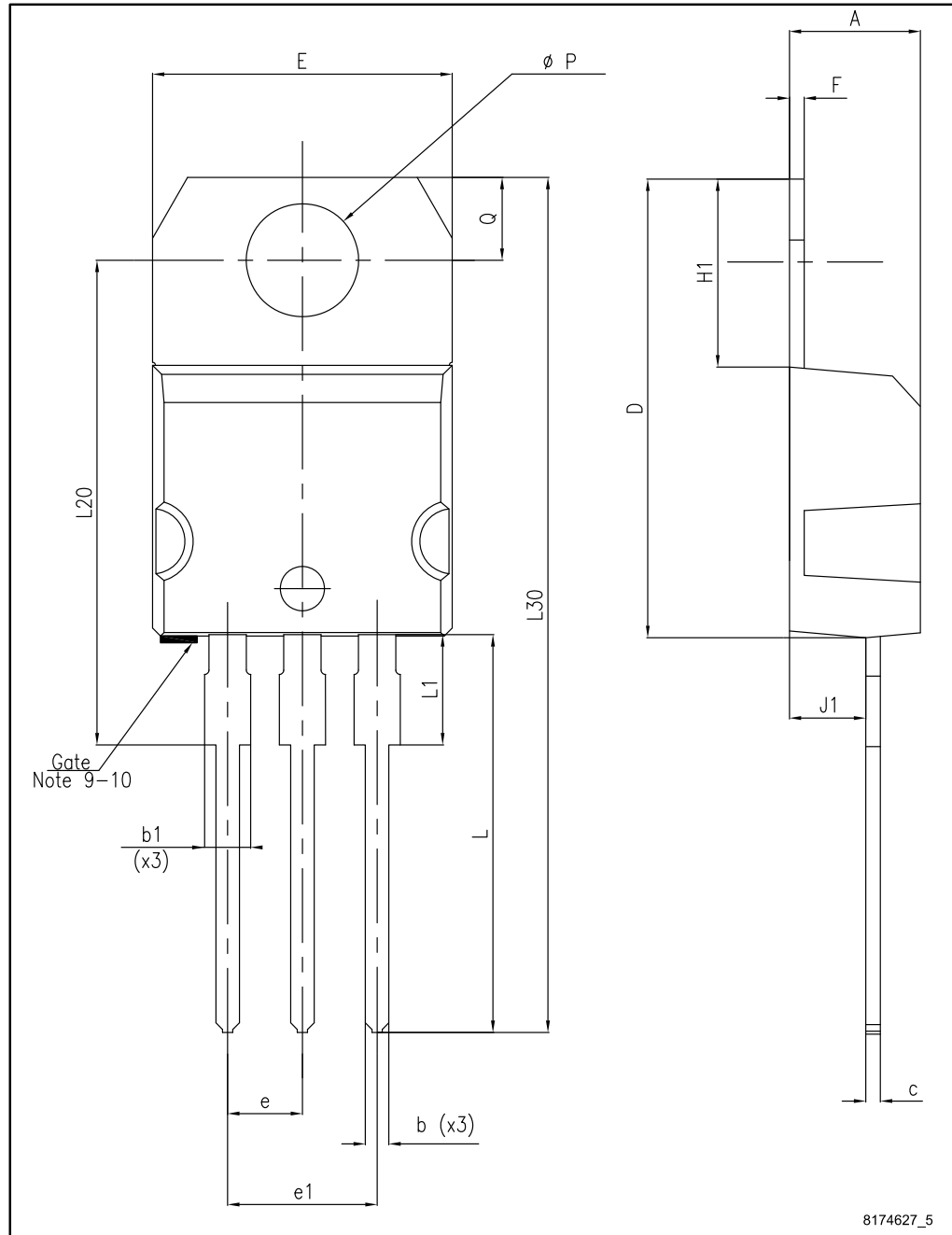
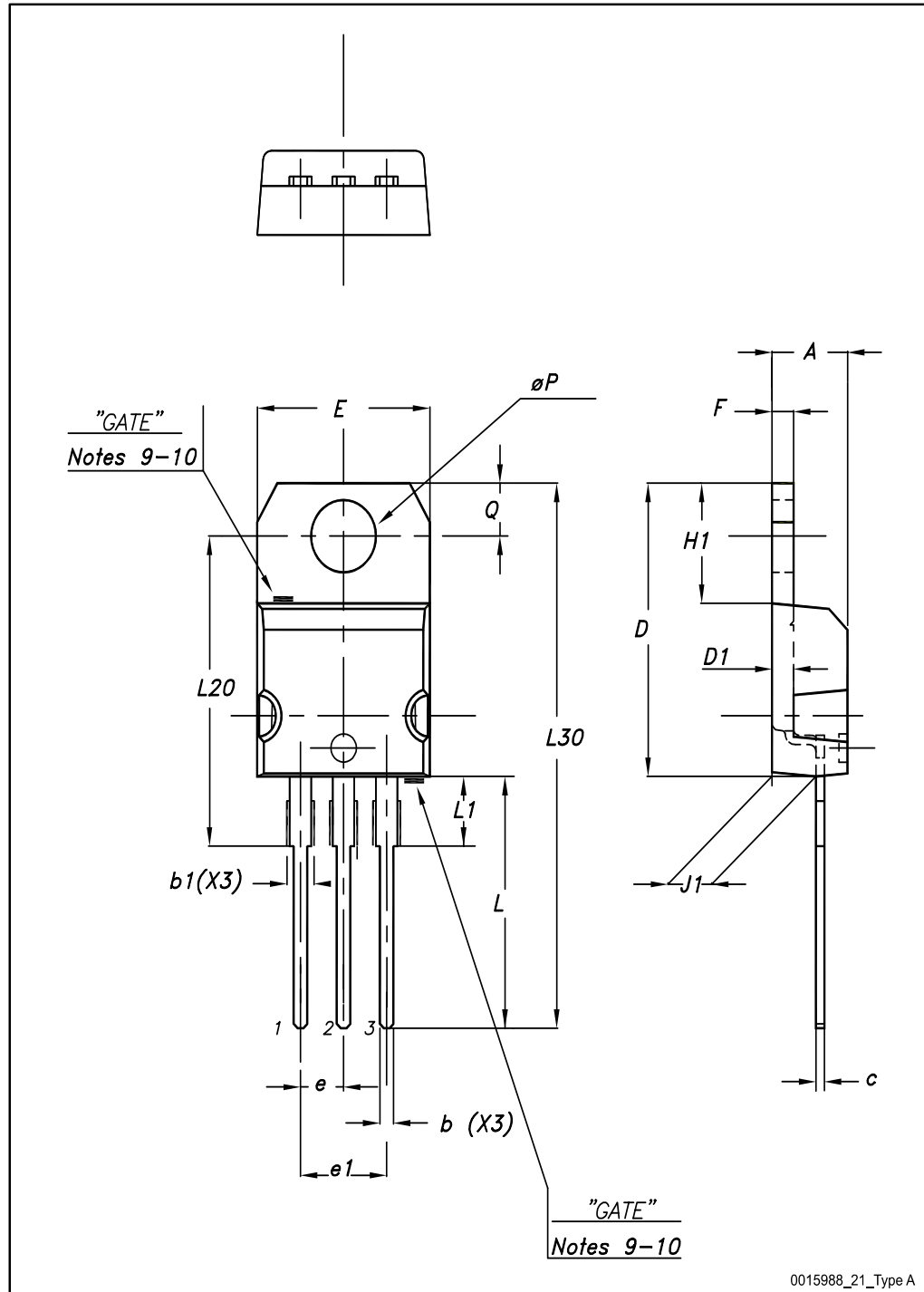

Table 18: TO-220 (single gauge) mechanical data

Dim.	mm		
	Min.	Typ.	Max.
A	4.40		4.60
b	0.61		0.88
b1	1.14		1.70
c	0.48		0.70
D	15.25		15.75
E	10.00		10.40
e	2.40		2.70
e1	4.95		5.15
F	0.51		0.60
H1	6.20		6.60
J1	2.40		2.72
L	13.00		14.00
L1	3.50		3.93
L20		16.40	
L30		28.90	
∅P	3.75		3.85
Q	2.65		2.95

## 8.2 TO-220 (dual gauge) package information

Figure 30: TO-220 (dual gauge) package outline



0015988\_21\_Type A

Table 19: TO-220 (dual gauge) mechanical data

Dim.	mm		
	Min.	Typ.	Max.
A	4.40		4.60
b	0.61		0.88
b1	1.14		1.70
c	0.48		0.70
D	15.25		15.75
D1		1.27	
E	10		10.40
e	2.40		2.70
e1	4.95		5.15
F	1.23		1.32
H1	6.20		6.60
J1	2.40		2.72
L	13		14
L1	3.50		3.93
L20		16.40	
L30		28.90	
∅P	3.75		3.85
Q	2.65		2.95



### 8.3 TO-220FP package information

Figure 31: TO-220FP package outline

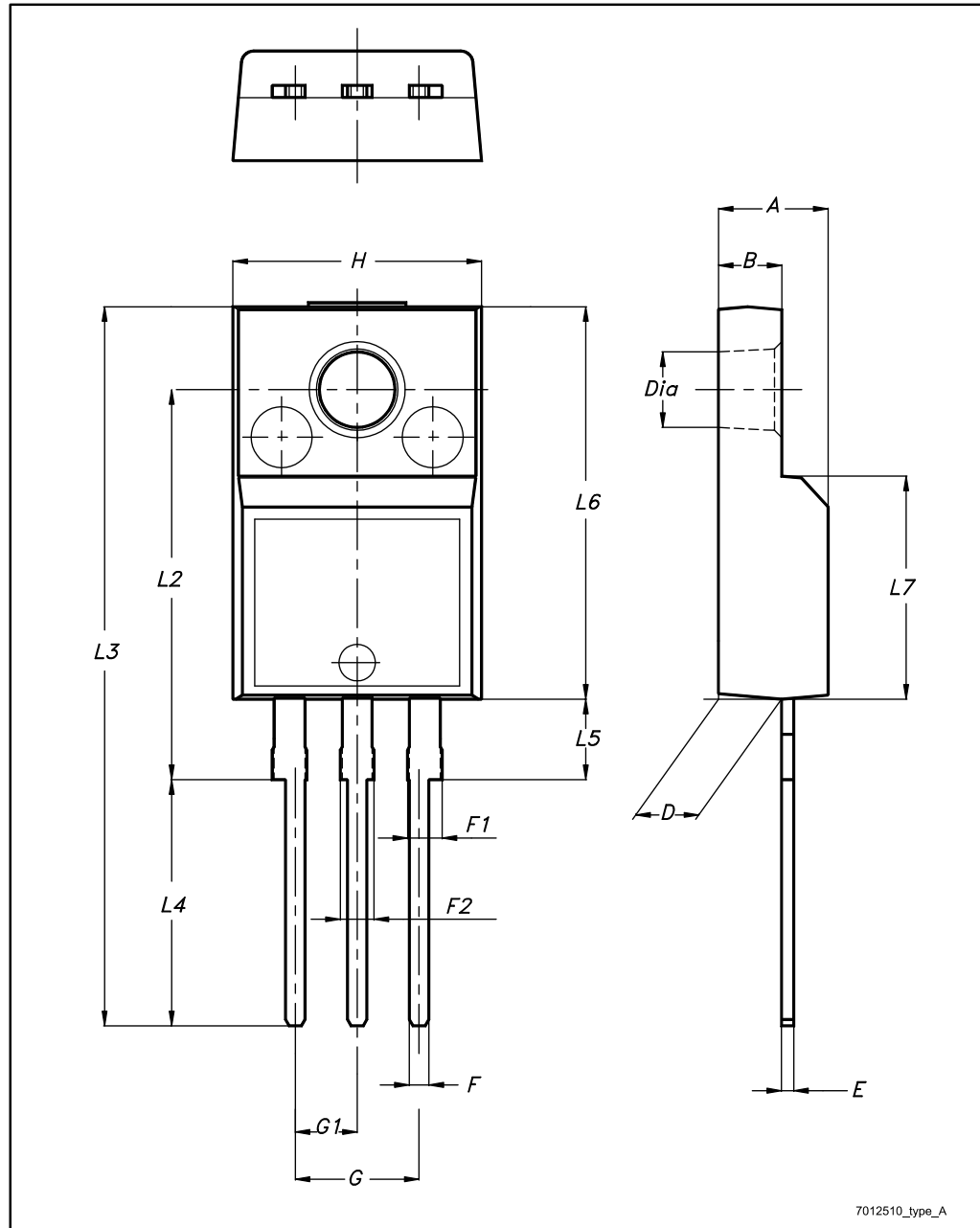

7012510\_type\_A

Table 20: TO-220FP package mechanical data

Dim.	mm		
	Min.	Typ.	Max.
A	4.4		4.6
B	2.5		2.7
D	2.5		2.75
E	0.45		0.7
F	0.75		1
F1	1.15		1.70
F2	1.15		1.70
G	4.95		5.2
G1	2.4		2.7
H	10		10.4
L2		16	
L3	28.6		30.6
L4	9.8		10.6
L5	2.9		3.6
L6	15.9		16.4
L7	9		9.3
Dia	3		3.2

## 8.4 DPAK (TO-252) type A package information

Figure 32: DPAK (TO-252) type A package outline

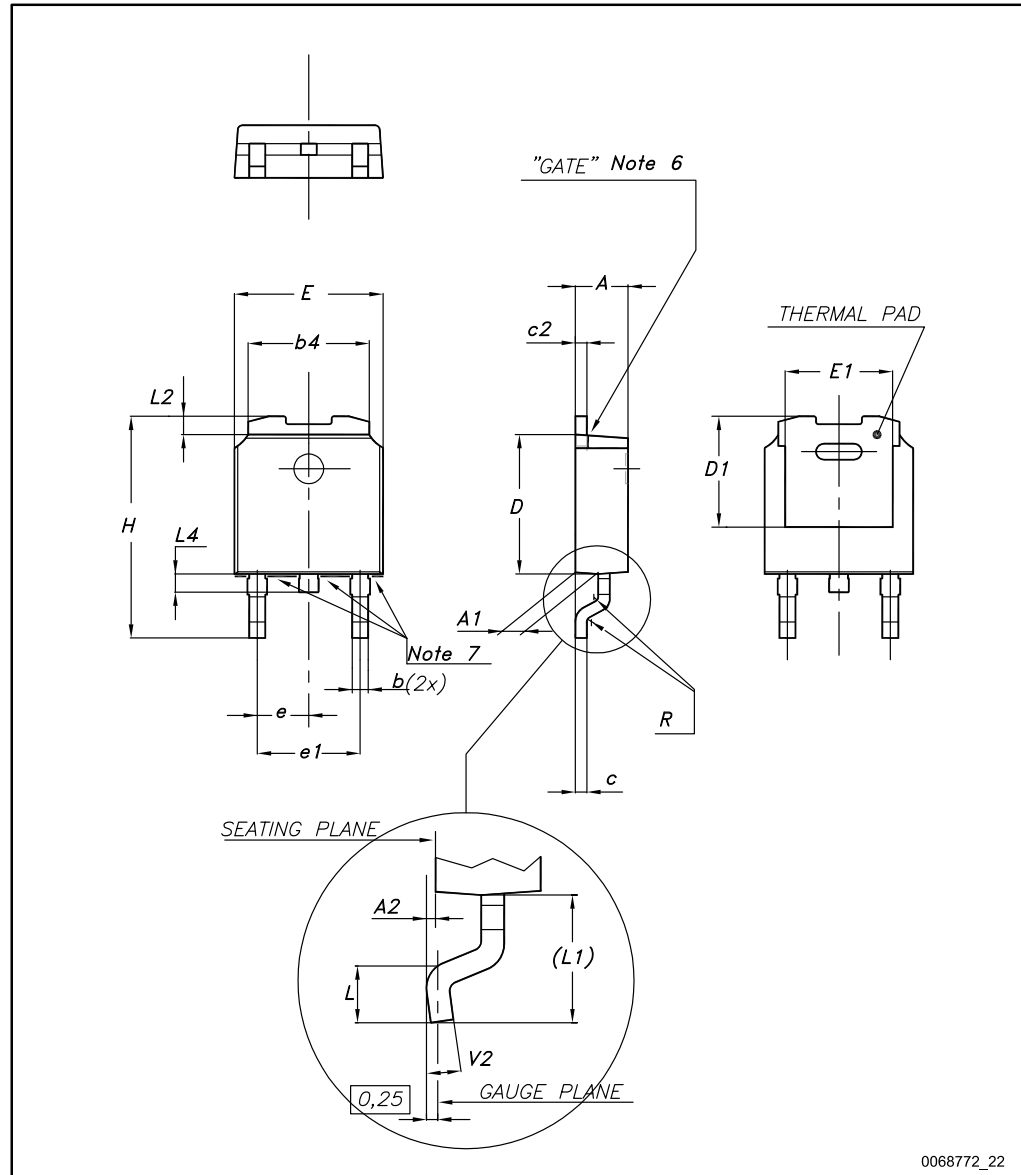
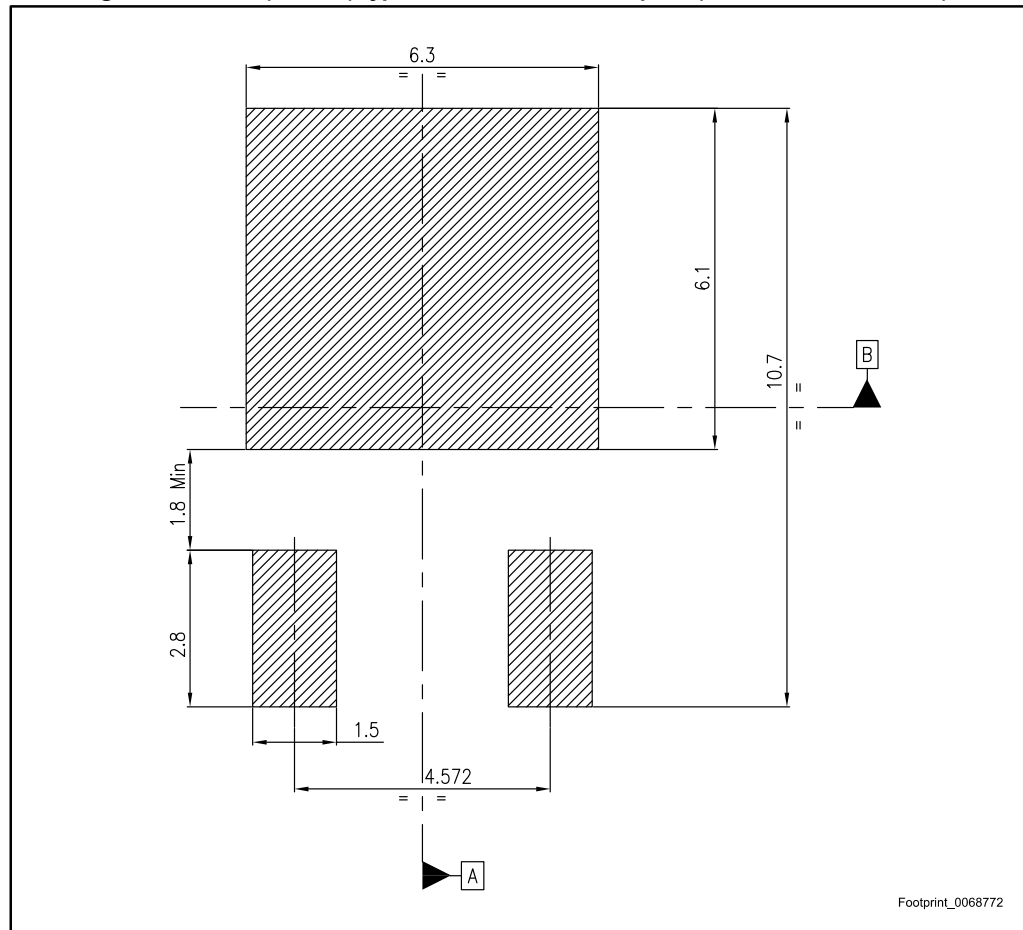

Table 21: DPAK (TO-252) type A mechanical data

Dim.	mm		
	Min.	Typ.	Max.
A	2.20		2.40
A1	0.90		1.10
A2	0.03		0.23
b	0.64		0.90
b4	5.20		5.40
c	0.45		0.60
c2	0.48		0.60
D	6.00		6.20
D1	4.95	5.10	5.25
E	6.40		6.60
E1	4.60	4.70	4.80
e	2.16	2.28	2.40
e1	4.40		4.60
H	9.35		10.10
L	1.00		1.50
(L1)	2.60	2.80	3.00
L2	0.65	0.80	0.95
L4	0.60		1.00
R		0.20	
V2	0°		8°

Figure 33: DPAK (TO-252) type A recommended footprint (dimensions are in mm)



### 8.5 DPAK (TO-252) type I package information

Figure 34: DPAK (TO-252) type I package outline

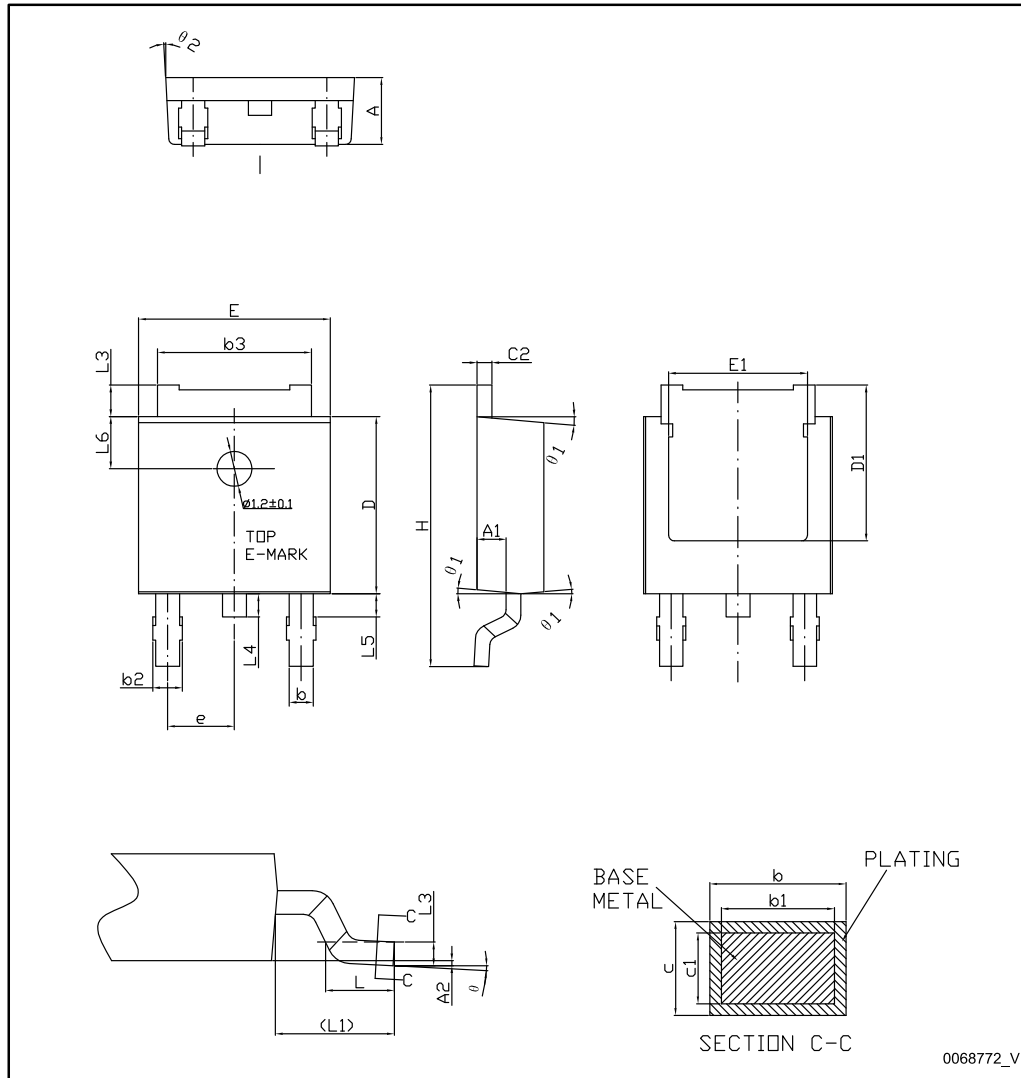
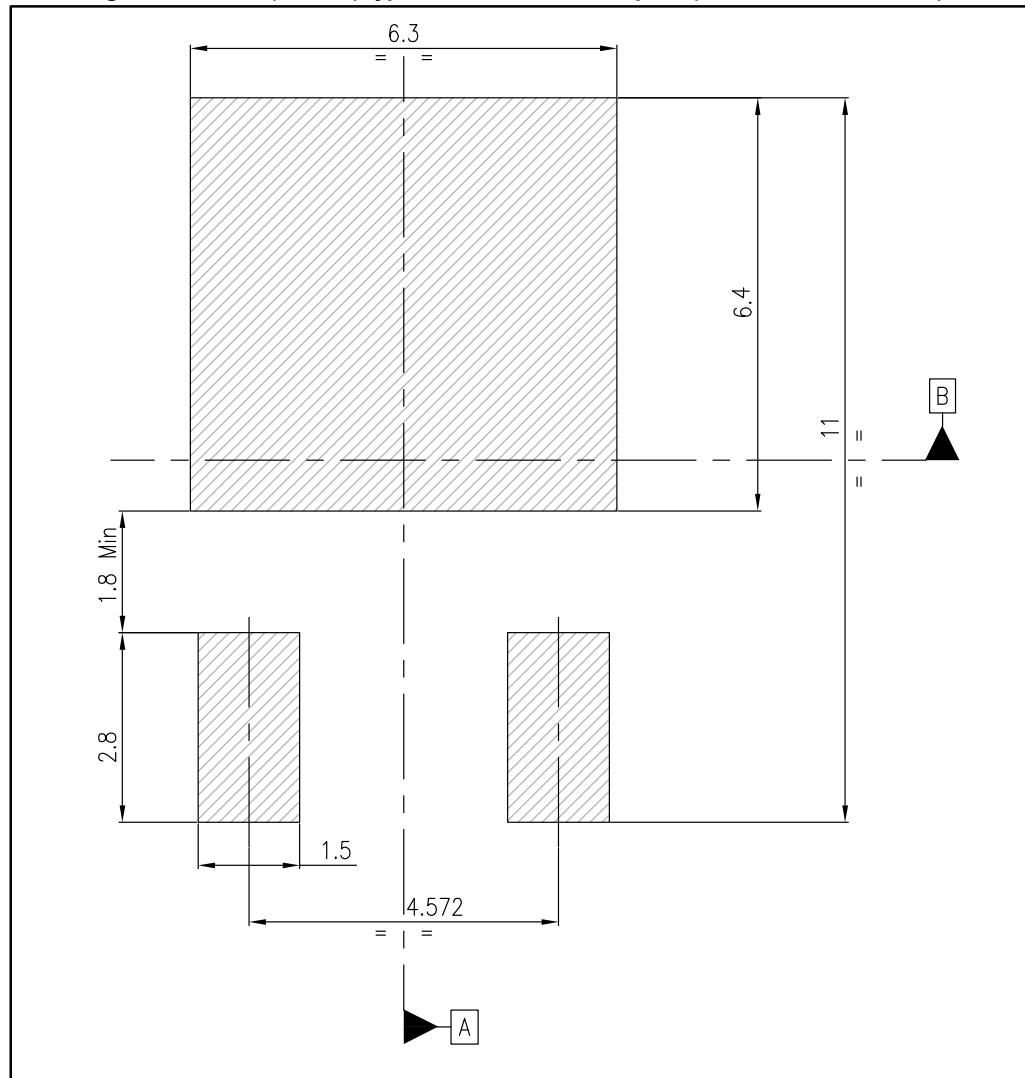

Table 22: DPAK (TO-252) type I mechanical data

Dim.	mm		
	Min.	Typ.	Max.
A	2.20	2.30	2.38
A1	0.90	1.01	1.10
A2	0.00	-	0.10
b	0.77	-	0.89
b1	0.76	0.81	0.86
b2	0.77	-	1.10
b3	5.23	5.33	5.43
c	0.47	-	0.60
c1	0.46	0.51	0.56
c2	0.47	-	0.60
D	6.00	6.10	6.20
D1	5.25	5.40	5.60
E	6.50	6.60	6.70
E1	4.70	4.85	5.00
e	2.286 BSC		
H	9.80	10.10	10.40
L	1.40	1.50	1.70
L1	2.90 REF		
L2	0.90	-	1.25
L3	0.51 BSC		
L4	0.60	0.80	1.00
L5	0.90	-	1.50
L6	1.80 BSC		
θ	0°	-	8°
θ	5°	7°	9°
θ	5°	7°	9°

Figure 35: DPAK (TO-252) type I recommended footprint (dimensions are in mm)





## 8.6 DPAK packing information

Figure 36: DPAK tape

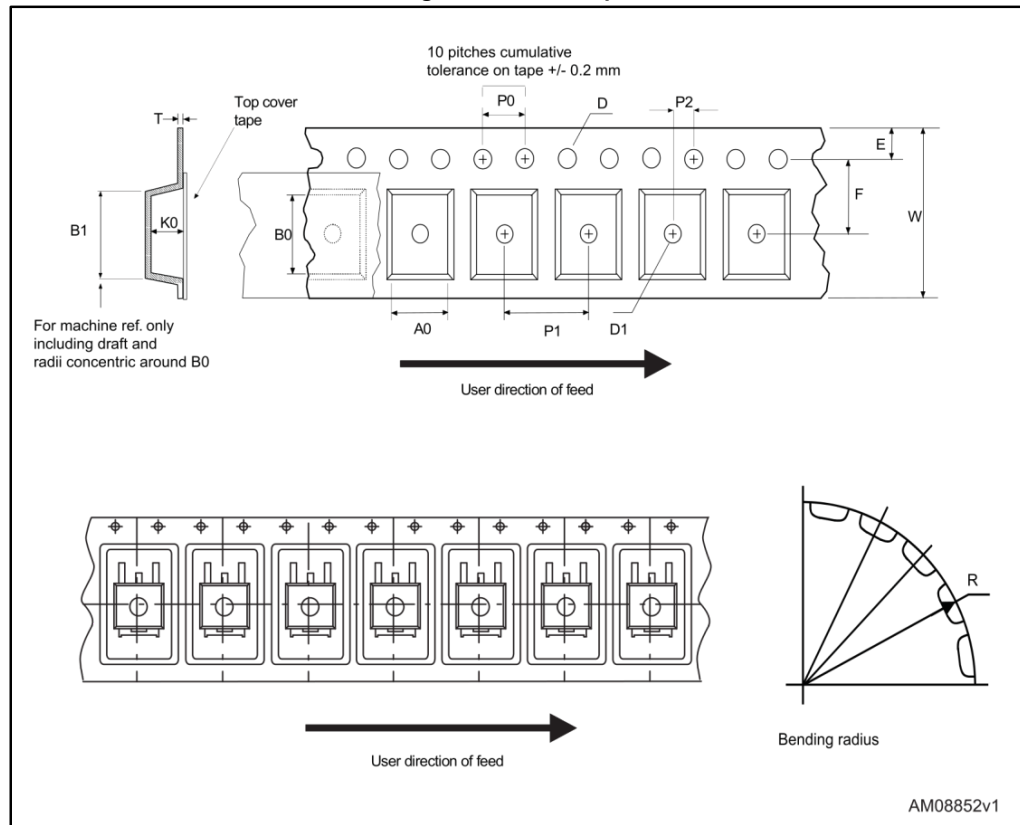

Figure 37: DPAK reel

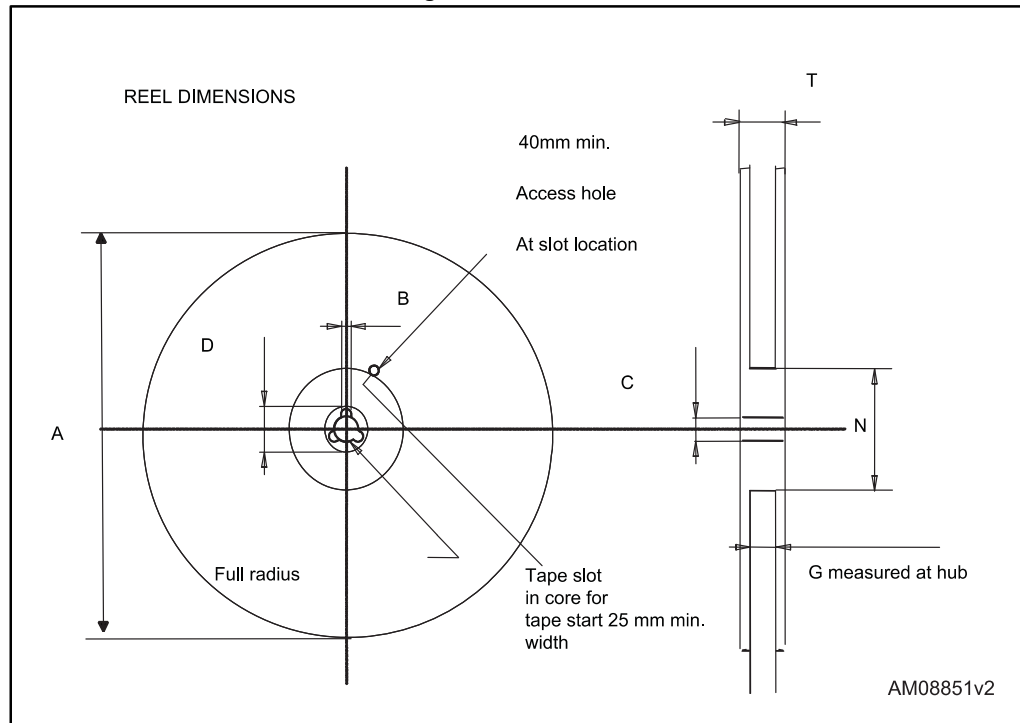

Table 23: DPAK tape and reel mechanical data

Tape			Reel		
Dim.	mm		Dim.	mm	
	Min.	Max.		Min.	Max.
A0	6.8	7	A		330
B0	10.4	10.6	B	1.5	
B1		12.1	C	12.8	13.2
D	1.5	1.6	D	20.2	
D1	1.5		G	16.4	18.4
E	1.65	1.85	N	50	
F	7.4	7.6	T		22.4
K0	2.55	2.75			
P0	3.9	4.1	Base qty.		2500
P1	7.9	8.1	Bulk qty.		2500
P2	1.9	2.1			
R	40				
T	0.25	0.35			
W	15.7	16.3			

### 8.7 IPAK package information

Figure 38: IPAK package outline

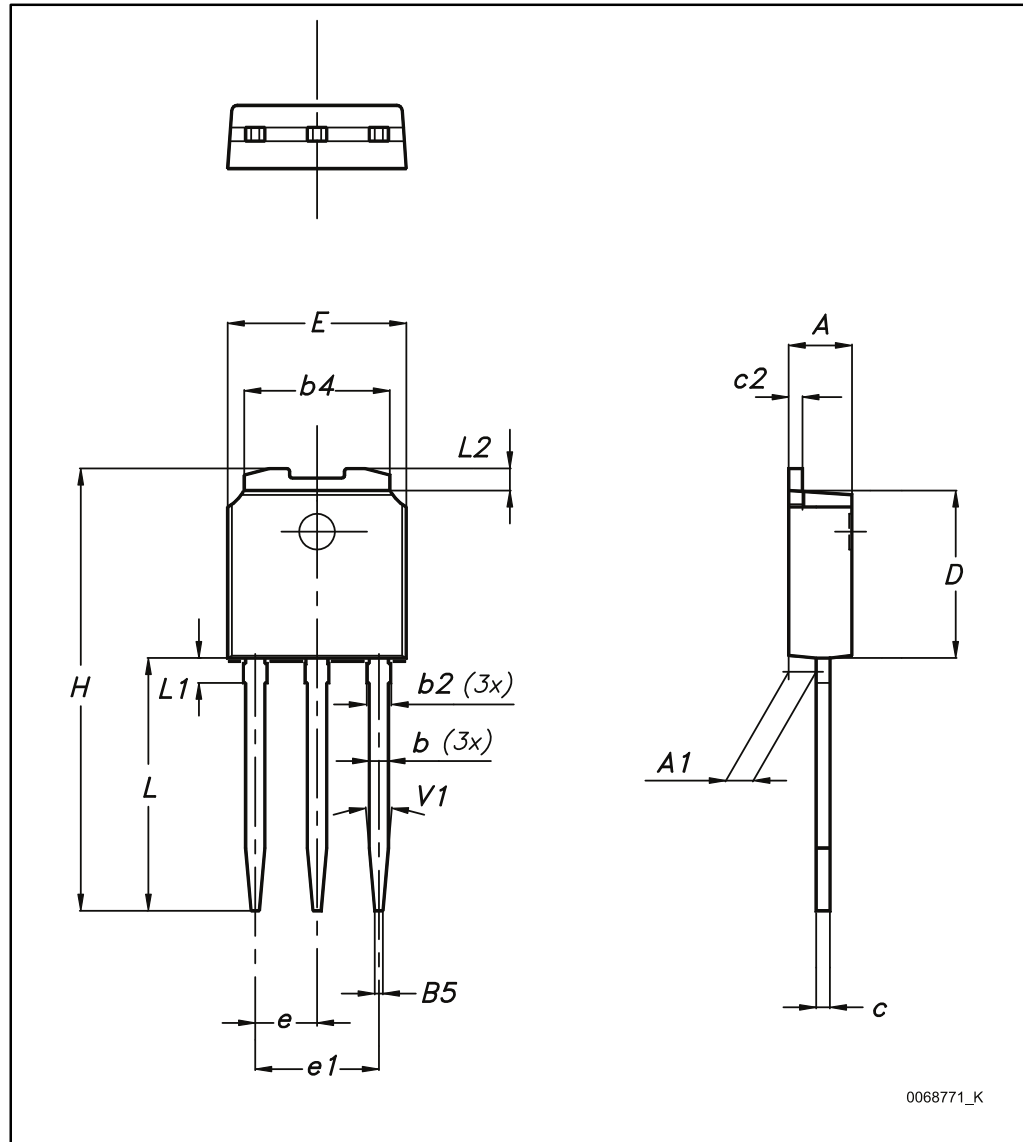

Table 24: IPAK mechanical data

Dim.	mm		
	Min.	Typ.	Max.
A	2.20		2.40
A1	0.90		1.10
b	0.64		0.90
b2			0.95
b4	5.20		5.40
B5		0.30	
c	0.45		0.60
c2	0.48		0.60
D	6.00		6.20
E	6.40		6.60
e		2.28	
e1	4.40		4.60
H		16.10	
L	9.00		9.40
L1	0.80		1.20
L2		0.80	1.00
V1		10°	

## 9 Ordering information

Table 25: Order code

Order codes					Output voltages
TO-220 (single gauge)	TO-220 (dual gauge)	TO-220FP	DPAK	IPAK	
L78M05ABV	L78M05ABV-DG		L78M05ABDT-TR		5 V
			L78M05ACDT-TR		
L78M05CV	L78M05CV-DG	L78M05CP	L78M05CDT-TR	L78M05CDT-1	5 V
			L78M06ABDT-TR		6 V
			L78M06CDT-TR		6 V
			L78M08ABDT-TR		8 V
L78M08CV	L78M08CV-DG		L78M08CDT-TR		8 V
			L78M09ABDT-TR		9 V
L78M09CV	L78M09CV-DG		L78M09CDT-TR		9 V
			L78M10ABDT-TR		10 V
			L78M12ABDT-TR		12 V
			L78M12ACDT-TR		12 V
L78M12CV	L78M12CV-DG		L78M12CDT-TR		12 V
L78M15ABV	L78M15ABV-DG		L78M15ABDT-TR		15 V
L78M15CV	L78M15CV-DG		L78M15CDT-TR		15 V
			L78M24ABDT-TR		24 V
			L78M24ACDT-TR		24 V
L78M24CV	L78M24CV-DG		L78M24CDT-TR		24 V

## 10 Revision history

Table 26: Document revision history

Date	Revision	Changes
21-Jun-2004	6	Document updating.
30-Aug-2006	7	Order codes updated.
29-Nov-2006	8	DPAK mechanical data updated and add footprint data.
06-Jun-2007	9	Order codes updated.
10-Dec-2007	10	Added Table 25.
19-Feb-2008	11	Modified: Table 25 on page 44.
15-Jul-2008	12	Modified: Table 25 on page 44 and Table 26 on page 45.
07-Apr-2009	13	Modified: Figure 9 on page 22 and Figure 15 on page 23.
14-Jun-2010	14	Added: Table 18 on page 26, Figure 29 on page 27, Figure 30 on page 28, Figure 31 and Figure 32 on page 29.
11-Nov-2010	15	Modified: $R_{thJC}$ value for TO-220 Table 2 on page 5.
08-Feb-2012	16	Added: order codes L78M05CV-DG, L78M12CV-DG and L78M15CV-DG Table 25 on page 44.
09-Mar-2012	17	Added: order codes L78M08CV-DG and L78M09CV-DG Table 25 on page 44.
15-May-2012	18	Added: order codes L78M24CV-DG Table 25 on page 44.
19-Apr-2013	19	Removed: Available on request footnote 2 Table 25 on page 44.
04-Jun-2014	20	Part numbers L78MxxAB, L78MxxAC and L78MxxC changed to L78M. Updated the title and the features in cover page. Canceled Table 1. Device summary. Updated Section 3: Maximum ratings, Section 5: Electrical characteristics, Section 6: Typical performance and Section 8: Package mechanical data. Added Section 7: Applications information and Section 9: Packaging mechanical data. Minor text changes.
21-Mar-2017	21	Updated <a href="#">Section 8: "Package information"</a> (DPAK package information changed from type F to type I). Minor text changes.

**IMPORTANT NOTICE – PLEASE READ CAREFULLY**

STMicroelectronics NV and its subsidiaries ("ST") reserve the right to make changes, corrections, enhancements, modifications, and improvements to ST products and/or to this document at any time without notice. Purchasers should obtain the latest relevant information on ST products before placing orders. ST products are sold pursuant to ST's terms and conditions of sale in place at the time of order acknowledgement.

Purchasers are solely responsible for the choice, selection, and use of ST products and ST assumes no liability for application assistance or the design of Purchasers' products.

No license, express or implied, to any intellectual property right is granted by ST herein.

Resale of ST products with provisions different from the information set forth herein shall void any warranty granted by ST for such product.

ST and the ST logo are trademarks of ST. All other product or service names are the property of their respective owners.

Information in this document supersedes and replaces information previously supplied in any prior versions of this document.

© 2017 STMicroelectronics – All rights reserved